

## **SESIND - Safety, alarm & indication unit**

The SESIND alarm unit is provided with a boiler safety system consisting of a relay chain. It was designed to be connected to any burner management and/or combustion control system and gives added safety especially to computerized control systems.

By means of jumpers at the terminals each alarm can be programmed either to be included in the boiler trip function or only to an alarm. The top alarm channel is the boiler trip alarm (sum alarm).

Each LED has a separate input which can be used for flashing light, double frequency at the first alarm or any other function created by the PLC in the combustion control system.

The SESIND unit features

- . 16 alarms including one "burner cut out" sum alarm
- . The boiler trip alarm has double output relays each with NC gold plated contacts
- . Each of the other alarms has potential free NC gold plated contacts
- . 16 indications model available (without alarm)
- . Highly luminous LEDs with wide observation angle
- . The SESIND unit has the standard measure 72 x 144 mm

Law in force protects S.E.S. Scandinavian Electronics AB property right to this drawing. The drawing or its contents must not be published, copied, multiplied, fabricated or improperly used otherwise.

51863101.dwg

05-12-12

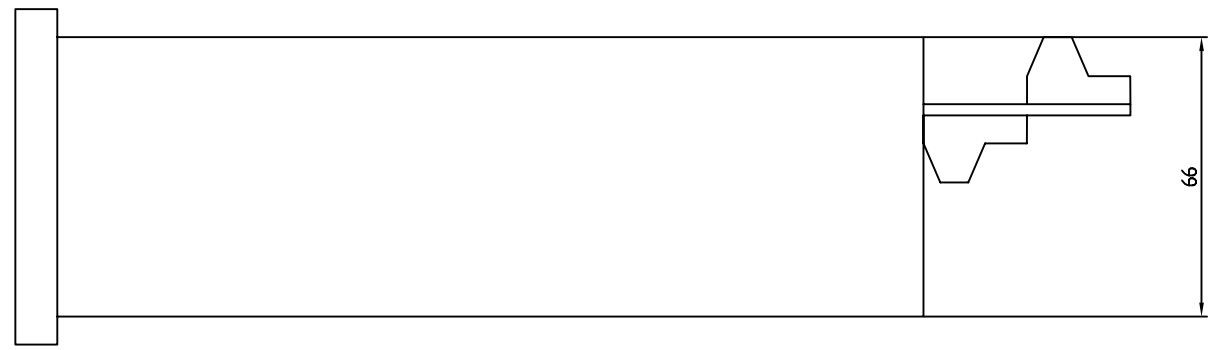
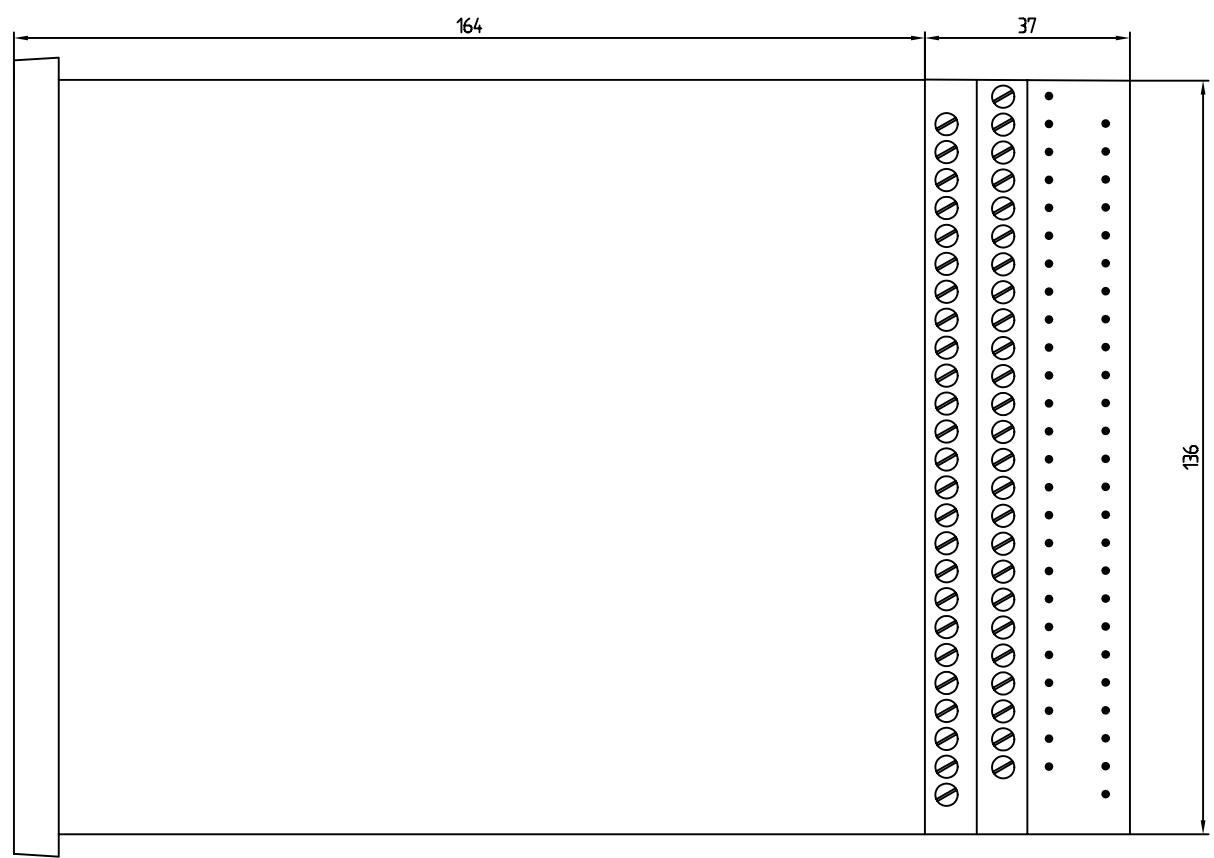
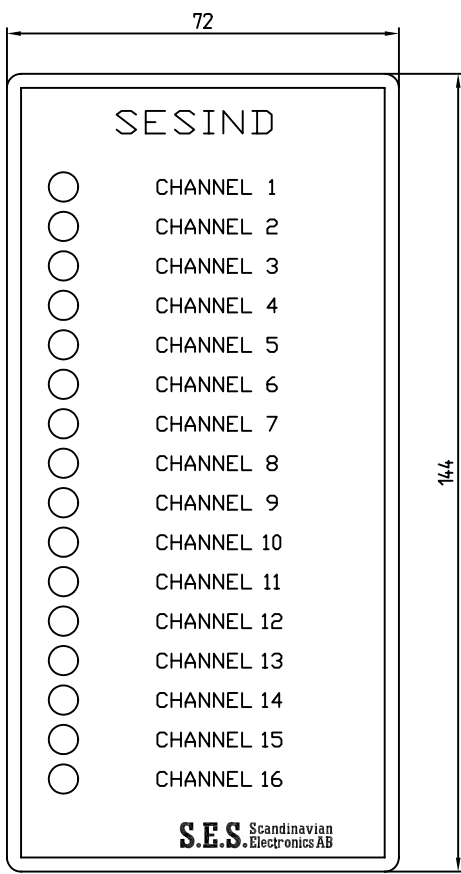

Anmärkningar/Remarks	Senaste Ändring/ Last revision	Anläggning/Plant SESIND				Jmf ritn/See drawing	Forts/Next sh 2
	Designation LARM & TRIP				Littera	Antbl/Tot sh	Blad/Sheet 1
Best nr/Order No.	<b>S.E.S.</b> Scandinavian Electronics AB			Konstr/Design	Gransk/Check	Godk/Approv	Ersätter/Replaces
				Datum/Date 2005-12-09	Fil nr/File No.		Ritning nr/Drawing No. 5186-31
							A3

Low In force protects S.E.S. Scandinavian Electronics AB property  
 without permission - be published, copied, multiplied,  
 reproduced or improperly used otherwise.

51863102.dwg

05-12-12

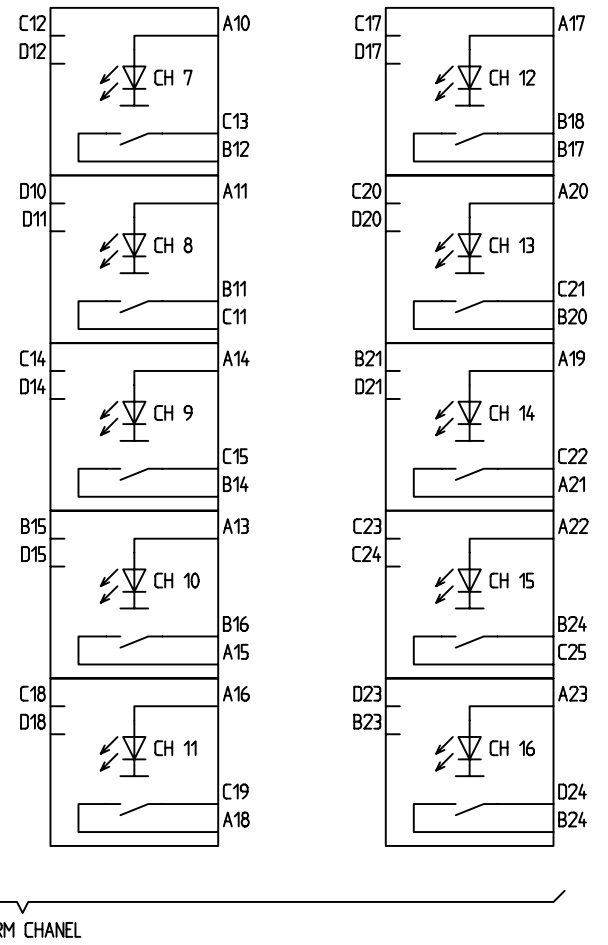
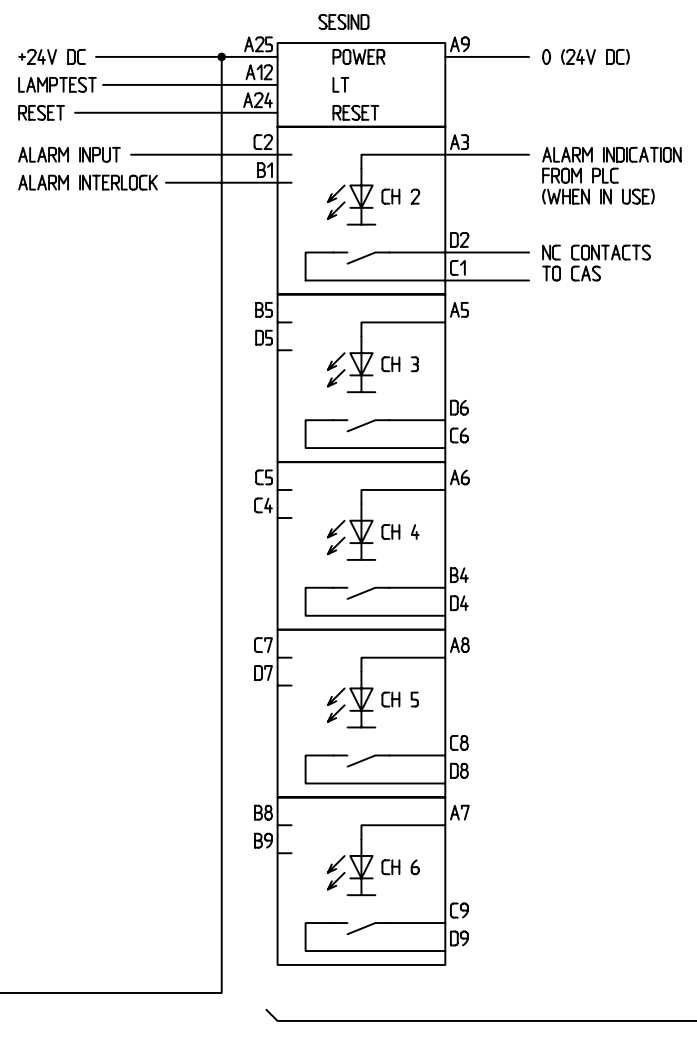
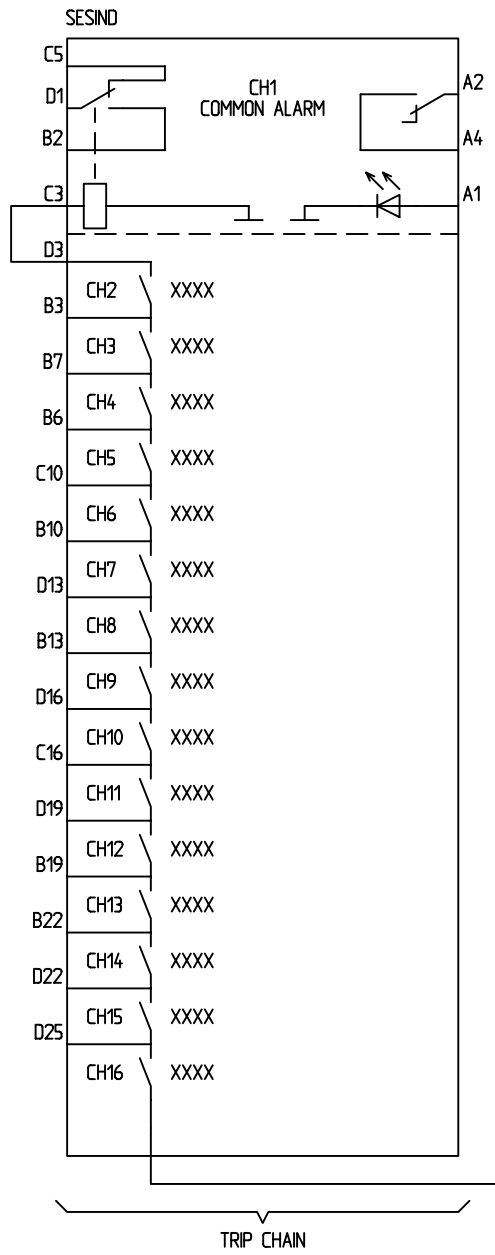

Anmärkning/Remarks THE UNIT IS FACTORY PROGRAMMED (LINKS IN P.C.B.) TO EITHER HAVE INDICATION FROM PLC OR INTERNAL INDICATION POWER SUPPLY (FIXED LIGHT ONLY)	Senaste Ändring/ Last revision	Anläggning/Plant SESIND				Jmf ritn/See drawing -		Forts/Next sh -	
	Best nr/Order No.	Designation LARM & TRIP				Littera	Antbl/Tot sh	Blad/Sheet 2	
<b>S.E.S. Scandinavian Electronics AB</b>		Konstr/Design	Gransk/Check	Godk/Approv	Ersätter/Replaces		Ritning nr/Drawing No.		Storl/ Size A3
		Datum/Date 2005-12-09		Fil nr/File No.		5186-31			

Law in force protects S.E.S. Scandinavian Electronics AB property  
 right to this drawing. The drawing or its contents must not  
 without permission be published, copied, multiplied,  
 fabricated or improperly used otherwise.

51873101DWG

05-12-13

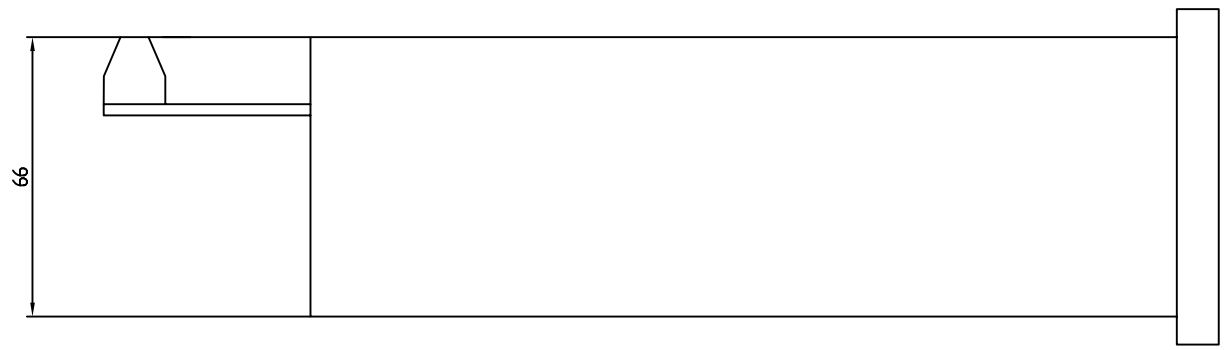
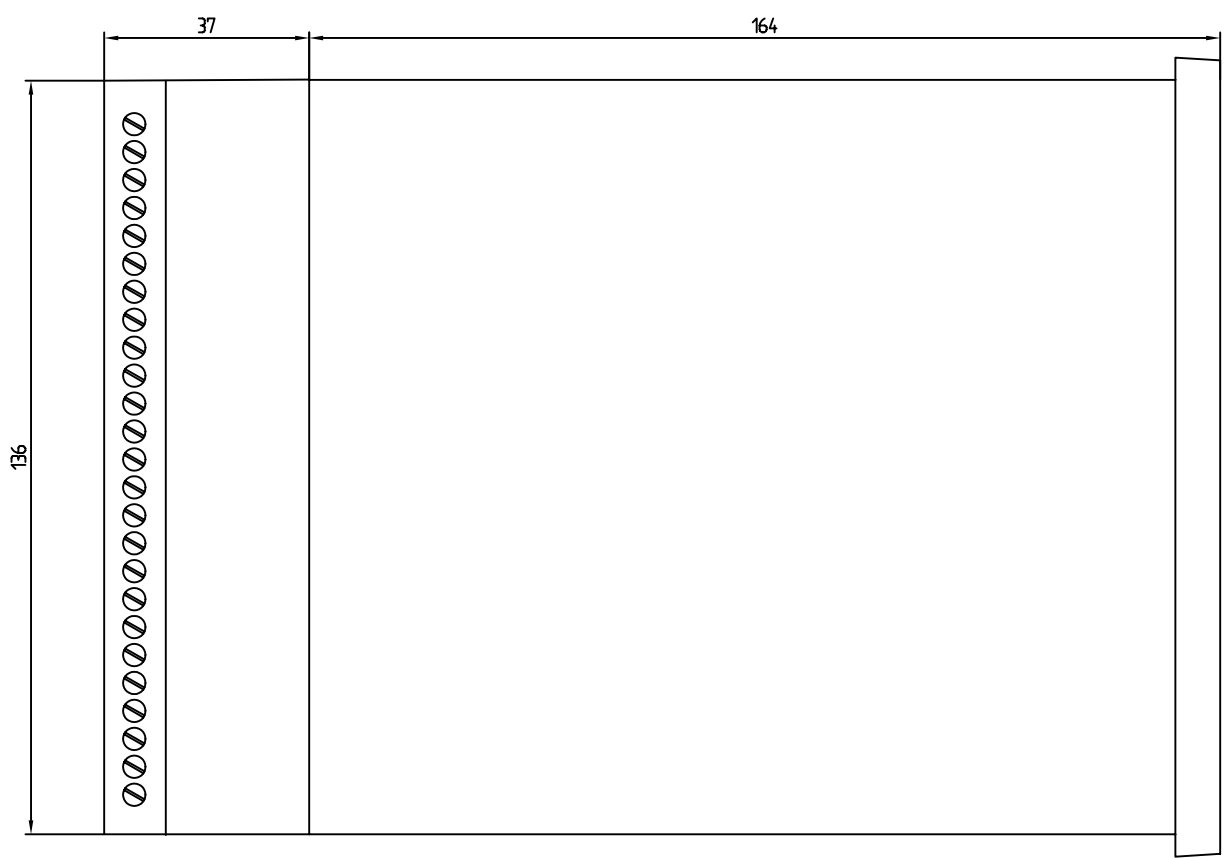
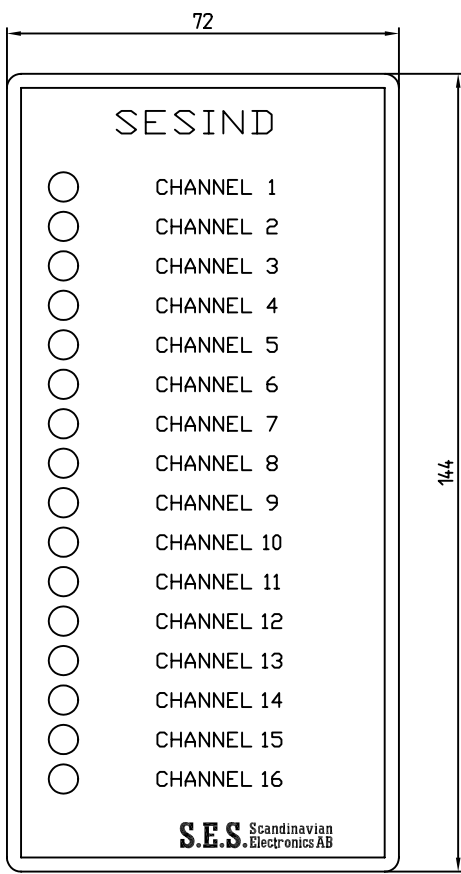

Anmärkningar/Remarks	Senaste Ändring/ Last revision	Anläggning/Plant SESIND				Jmf ritn/See drawing		Forts/Next sh 2		
		Designation INDICATION				Littera	Antbl/Tot sh	Blad/Sheet 1		
	Best nr/Order No.	<b>S.E.S.</b> Scandinavian Electronics AB			Konstr/Design	Gransk/Check	Godk/Approv	Ersätter/Replaces	Ritning nr/Drawing No. 5187-31	Storl/ Size A3
					Datum/Date 2005-12-09		Fil nr/File No.			

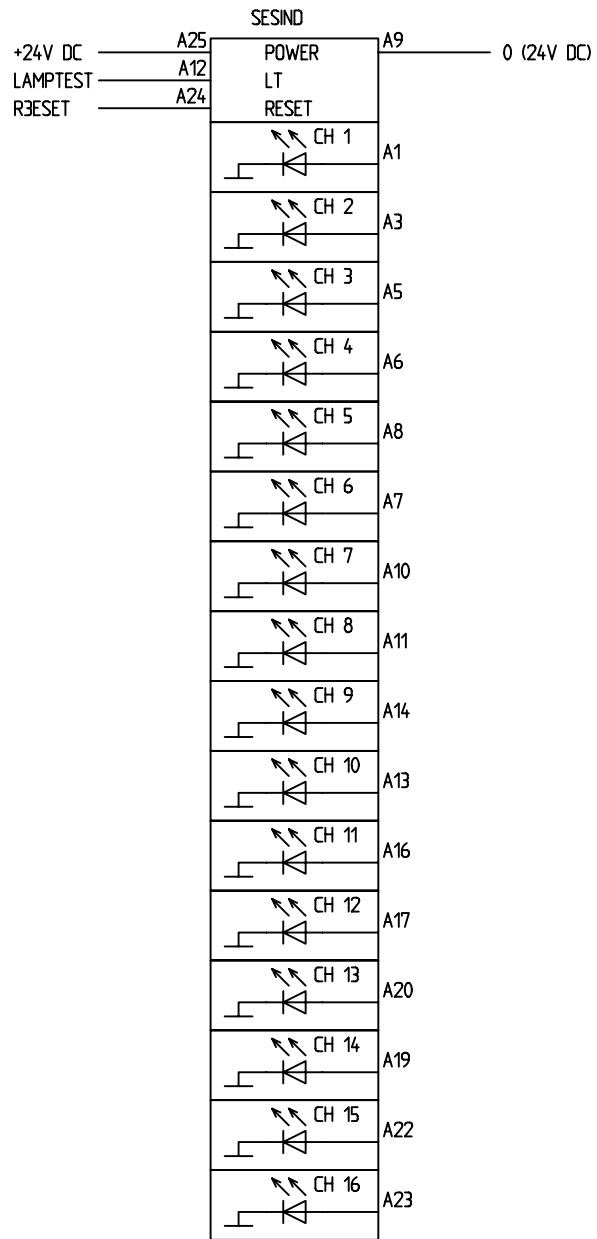

Law in force protects S.E.S. Scandinavian Electronics AB property  
 right to this drawing. The drawing or its contents must not  
 without permission be published, copied, multiplied,  
 fabricated or improperly used otherwise.

51873102.dwg

05-12-13

Anmärkningar/Remarks	Senaste Ändring/ Last revision	Anläggning/Plant SESIND				Jmf ritn/See drawing		Forts/Next sh —		
		Designation INDICATION				Littera	Antbl/Tot sh	Blad/Sheet 2		
	Best nr/Order No.	<b>S.E.S. Scandinavian Electronics AB</b>			Konstr/Design	Gransk/Check	Godk/Approv	Ersätter/Replaces	Ritning nr/Drawing No.  5187-31	Storl/ Size  A3
					Datum/Date 2005-12-09		Fil nr/File No.			

# SESIND

- CHANNEL 1
- CHANNEL 2
- CHANNEL 3
- CHANNEL 4
- CHANNEL 5
- CHANNEL 6
- CHANNEL 7
- CHANNEL 8
- CHANNEL 9
- CHANNEL 10
- CHANNEL 11
- CHANNEL 12
- CHANNEL 13
- CHANNEL 14
- CHANNEL 15
- CHANNEL 16

**S.E.S.** Scandinavian  
Electronics AB

Anmärkningar/Remarks	Senaste Ändring/ Last revision	Anläggning/Plant SESIND, LARM & TRIP				Jmf ritn/See drawing	Forts/Next sh 2
	Best nr/Order No.	Designation SESIND LAYOUT				Littera	Antbl/Tot sh 1
<b>S.E.S.</b> Scandinavian Electronics AB		Konstr/Design	Gransk/Check	Godk/Approv	Ersätter/Replaces	Ritning nr/Drawing No. 3021-31	Storl/ Size A3
		Datum/Date 1994-10-15		Fil nr/File No. 30213101.DWG			

Law in force protects S.E.S. Scandinavian Electronics AB property  
 right to this drawing. The drawing or its contents must not be  
 without permission - be published, copied, multiplied,  
 fabricated or improperly used otherwise.

Low In force protects S.E.S. Scandinavian Electronics AB property  
 right to this drawing. The drawing or its contents must not  
 without permission be published, copied, multiplied,  
 fabricated or improperly used otherwise.

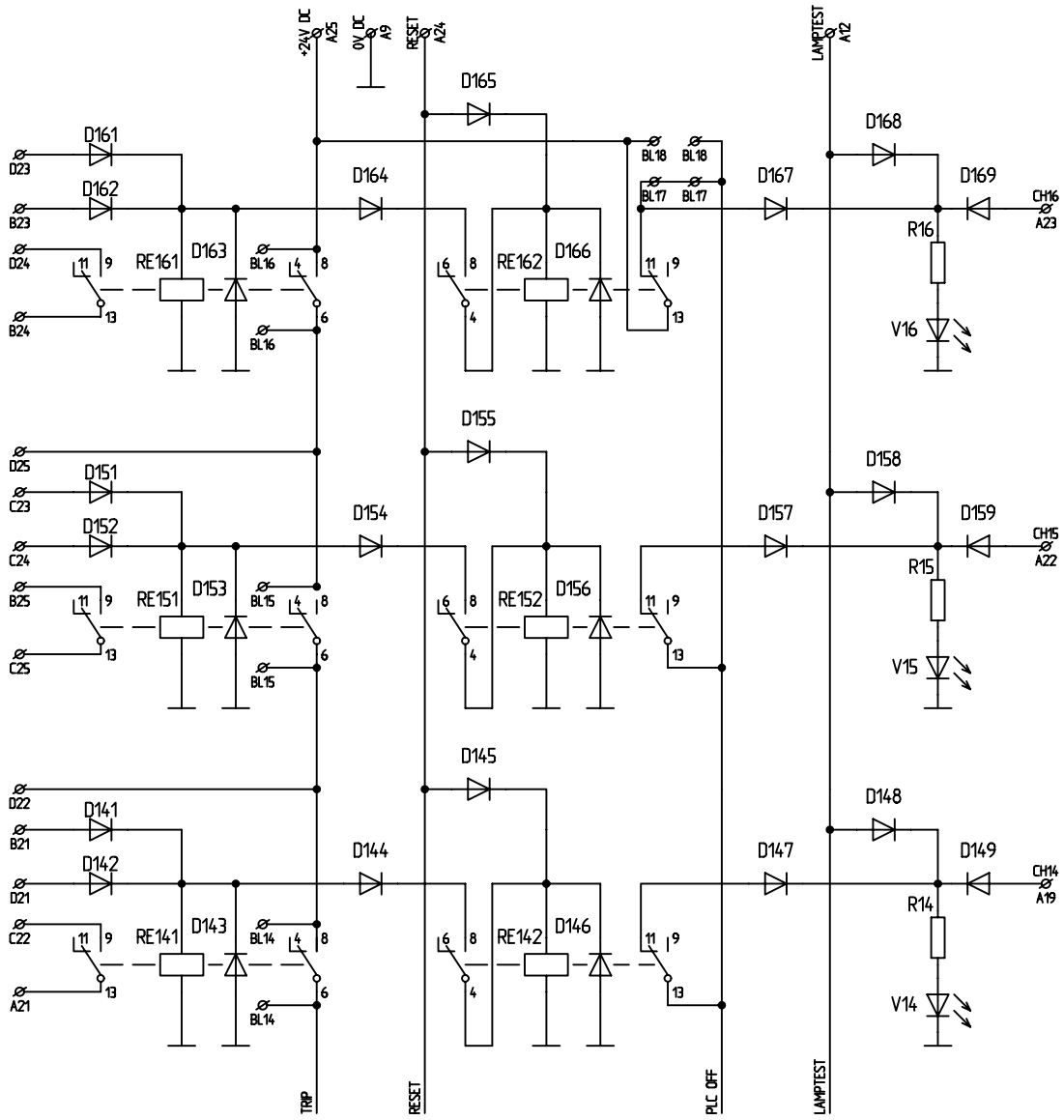

Anmärkingar/Remarks

Senaste Ändring/  
Last revision

Anläggning/Plant

SESIND, LARM & TRIP

Designation

SESIND WIRING DIAGRAM

Jmf ritn/See drawing

Forts/Next sh

3

Littera

Antbl/Tot sh

Blad/Sheet

2

Best nr/Order No.

**S.E.S.** Scandinavian  
Electronics AB

Konstr/Design

Gransk/Check

Godk/Approv

Ersätter/Replaces

Ritning nr/Drawing No.

Storl/  
Size

Datum/Date

1994-10-15

Fil nr/File No.

30213102.DWG

3021-31

A3

Low In force protects S.E.S. Scandinavian Electronics AB property  
 Right to this drawing - be published, copied, multiplied,  
 without permission - be published, copied, multiplied,  
 fabricated or improperly used otherwise.

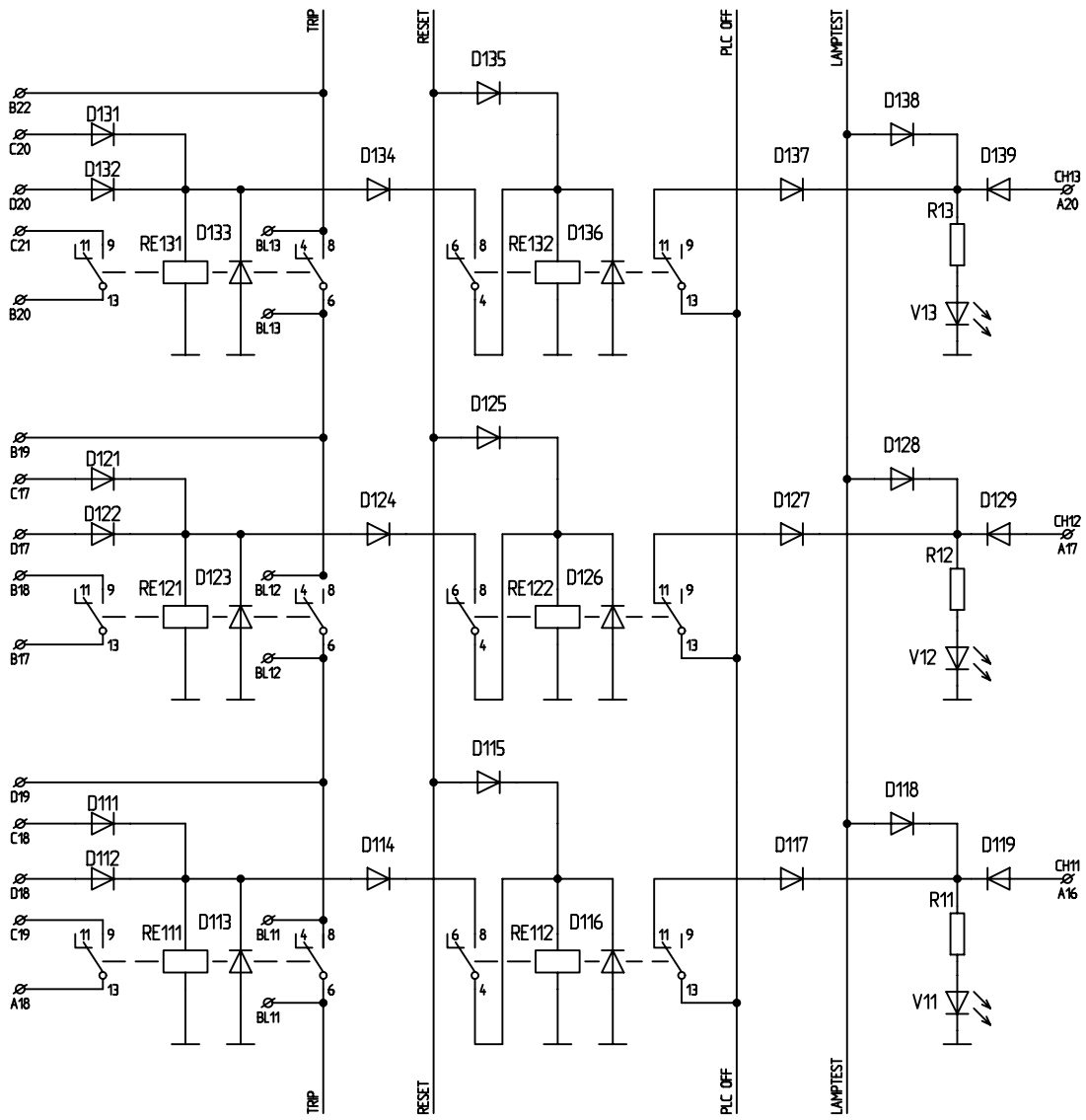

Anmärkning/Remarks

Senaste Ändring/  
Last revision

Anläggning/Plant

SESIND, LARM & TRIP

Jmf ritn/See drawing

Forts/Next sh

4

Designation

SESIND WIRING DIAGRAM

Littera

Antbl/Tot sh

Blad/Sheet

3

Best nr/Order No.

**S.E.S.** Scandinavian  
Electronics AB

Konstr/Design

Gransk/Check

Godk/Approv

Ersätter/Replaces

Ritning nr/Drawing No.

Storl/  
Size

Datum/Date

1994-10-15

Fil nr/File No.

30213103.DWG

3021-31

A3

Low In force protects S.E.S. Scandinavian Electronics AB property.  
 Right to this drawing - be published, copied, multiplied,  
 without permission - be published, copied, multiplied,  
 fabricated or improperly used otherwise.

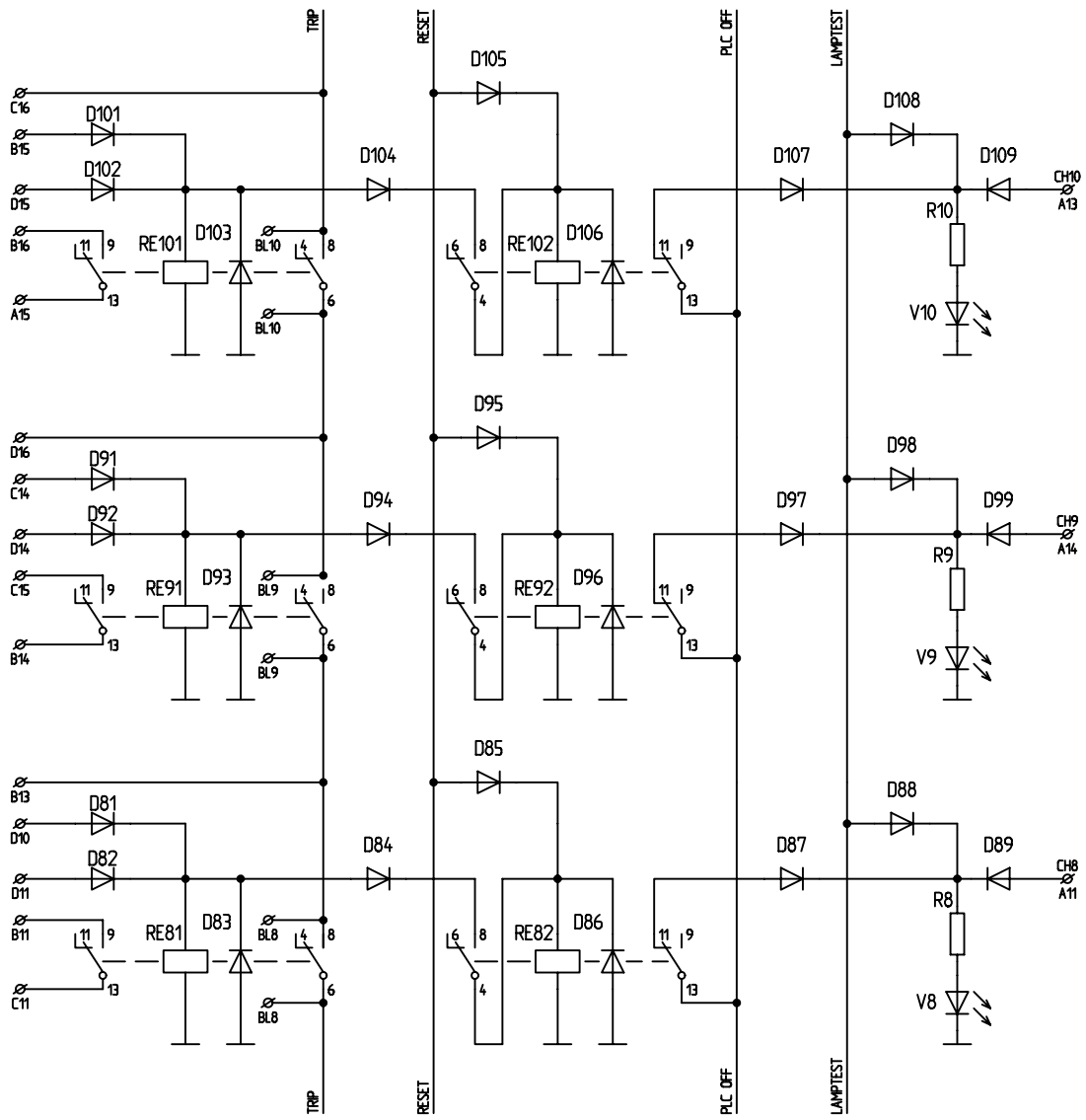

Anmärkningar/Remarks	Senaste Ändring/ Last revision	Anläggning/Plant SESIND, LARM & TRIP				Jmf ritn/See drawing	Forts/Next sh 5
	Best nr/Order No.	Designation SESIND WIRING DIAGRAM				Littera	Antbl/Tot sh 4
					Konstr/Design	Gransk/Check	Godk/Approv
			Datum/Date	1994-10-15		Fil nr/File No. 30213104.DWG	Ritning nr/Drawing No. 3021-31
							Storl/ Size A3

Low In force protects S.E.S. Scandinavian Electronics AB property  
 Right to this drawing - be published, copied, multiplied,  
 without permission - be published, copied, multiplied,  
 fabricated or improperly used otherwise.

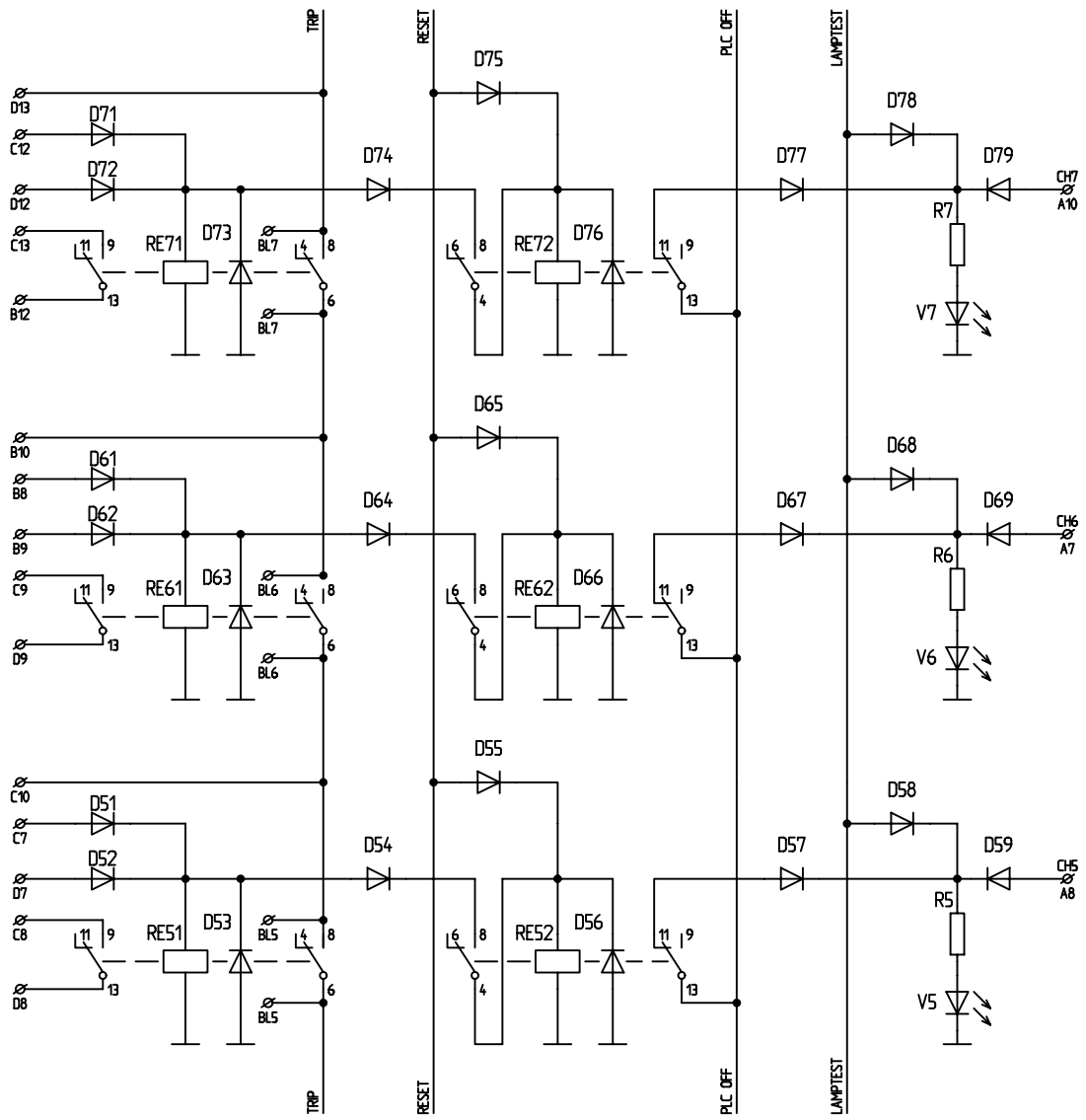

Anmärkingar/Remarks

Senaste Ändring/  
Last revision

Anläggning/Plant

SESIND, LARM & TRIP

Jmf ritn/See drawing

Forts/Next sh

6

Designation

SESIND WIRING DIAGRAM

Littera

Antbl/Tot sh

Blad/Sheet

5

Best nr/Order No.

**S.E.S.** Scandinavian  
Electronics AB

Konstr/Design

Gransk/Check

Godk/Approv

Ersätter/Replaces

Ritning nr/Drawing No.

Storl/  
Size

Datum/Date

1994-10-15

Fil nr/File No.

30213105.DWG

3021-31

A3

Law in force protects S.E.S. Scandinavian Electronics AB property  
 right to this drawing - The drawing or its contents must not -  
 without permission - be published, copied, multiplied,  
 fabricated or improperly used otherwise.

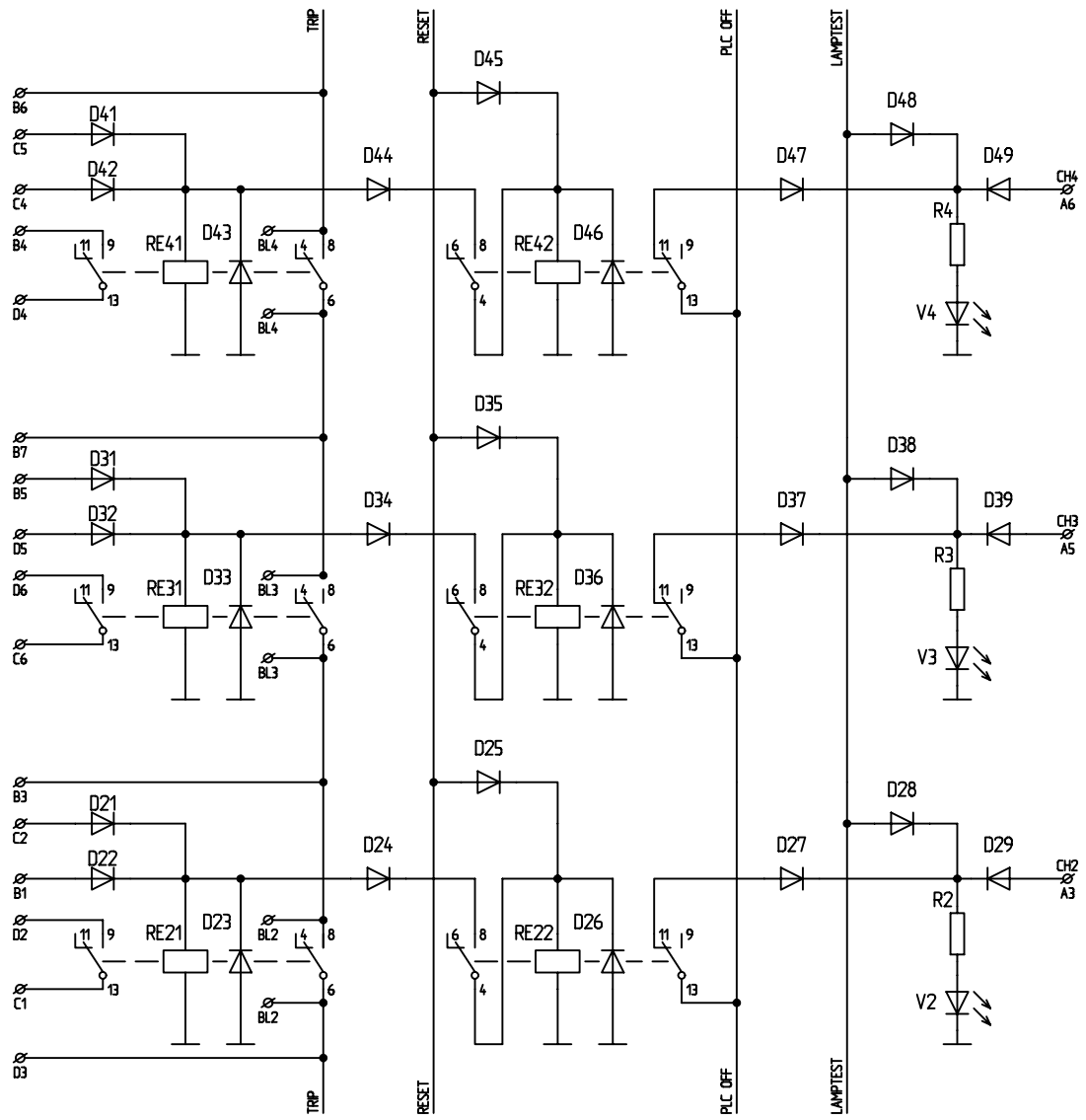

Anmärkningar/Remarks	Senaste Ändring/ Last revision	Anläggning/Plant SESIND, LARM & TRIP				Jmf ritn/See drawing	Forts/Next sh 7
		Designation SESIND WIRING DIAGRAM				Littera	Antbl/Tot sh Blad/Sheet 6
	Best nr/Order No.	<b>S.E.S.</b> Scandinavian Electronics AB		Konstr/Design	Gransk/Check	Godk/Approv	Ersätter/Replaces
				Datum/Date 1994-10-15	Fil nr/File No. 30213106.DWG	Ritning nr/Drawing No. 3021-31	

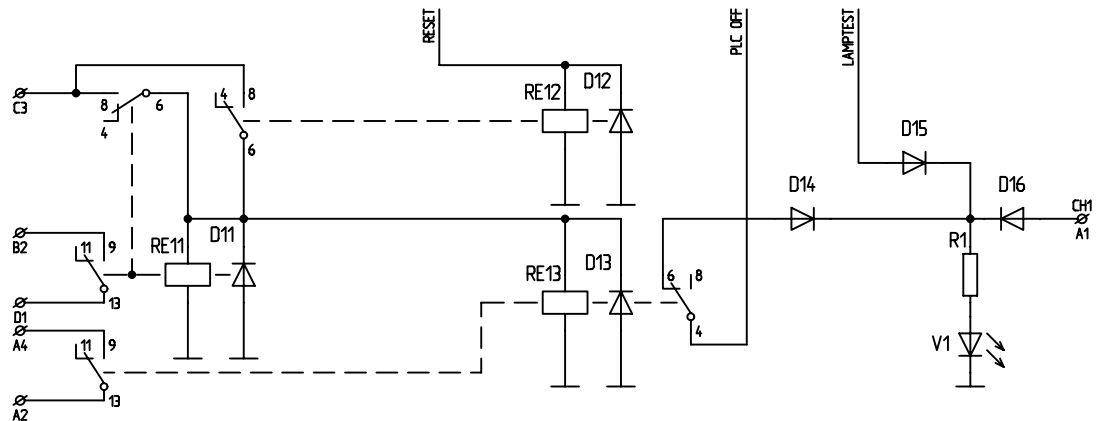

All in force projects S.E.S. Scandinavian Electronics AB property.  
 Right to this drawing - be published, copied, multiplied,  
 without permission - be published, copied, multiplied,  
 fabricated or improperly used otherwise.

Anmärkningar/Remarks	Senaste Ändring/ Last revision	Anläggning/Plant SESIND, LARM & TRIP				Jmf ritn/See drawing	Forts/Next sh —	
		Designation SESIND WIRING DIAGRAM				Littera	Antbl/Tot sh	Blad/Sheet 7
	Best nr/Order No.	<b>S.E.S. Scandinavian Electronics AB</b>			Konstr/Design	Gransk/Check	Godk/Approv	Ersätter/Replaces
					Datum/Date	1994-10-15		Fill nr/File No.
					Ritning nr/Drawing No.		3021-31	
							Storl/ Size A3	