



Heavy Duty Gas Igniter

Maximum heat release: 4 kW (14,000 BTU/hr)
Ionisation monitored

Model **ZGU...**

Table of Contents

1. Part Numbering System	3
2. Technical Data	4
3. Storage, Installation Instructions and Lifetime	4
4. Flame Monitoring	4
5. Construction According to Sectional Drawing.....	5
6. Available Spare Parts and Wear and Tear Parts.....	6
7. Accessories	7
8. Setting the Required Gas and Air Flow.....	7
9. Maintenance and Alignment.....	7
10. Electrical Function Test (without Flame) Using A10Z2 Test Diode	8
11. Gas- and Air-Regulating Components (to be ordered separately)	8
12. Troubleshooting	9
13. Approvals	12

Note

- ***Please read this manual and adhere to it when making use of the device***
- ***Installation and maintenance procedures may only be carried out by authorized personnel***
- ***All local regulations and the prevailing codes of practice must be observed during installation.***
- ***Improper installation, alignment and maintenance, as well as modifications by the customer, can all lead to personal injury or property damage, as well as loss of warranty!***

1. Part Numbering System

The example below shows how the most important igniter information is incorporated into the part number:

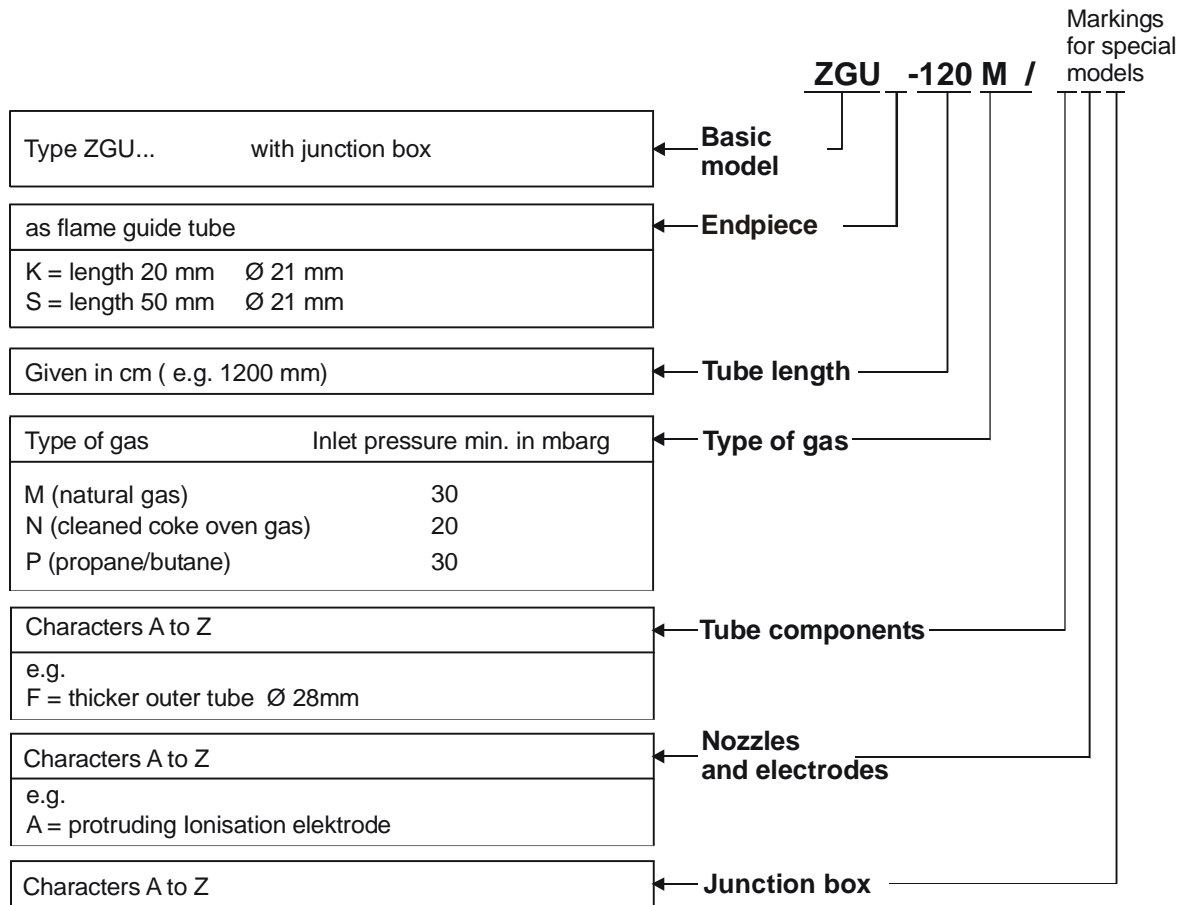

2. Technical Data

Burner Part

Heat release	max. 4 kW (14,000 BTU/hr)
Flame length.....	max. 100 mm (approx. 4")
Tube length.....	available in increments of 120 mm, length 120 – 3960 mm
Gas connection	1/4", from left or right (design pressure max. 10bar)
Gas flow, appr.	1 m ³ /h manufactured gas 0,4 m ³ /h natural gas 0,17 m ³ /h propane
Air connection.....	3/8", may be rotated in increments of 90°
Air flow	max. 4 m ³ /h
Maximum ambient temperature	igniter tube: 500°C (932°F); if temperature is higher, combustion air 20% min. must be left on to serve as cooling air. At temperatures > 700°C (1292°F), additional cooling air must be supplied in the gap between the guide tube and igniter tube.
Maximum back pressure	200 mbarg inside the igniter housing

Junction Room

Cable entry.....	junction room with 2 cable glands Pg 9
Spark.....	5 kV electrode to earth (by separate spark transformer)
Protection.....	IP 54

3. Storage, Installation Instructions and Lifetime

Igniters are to be stored in a dry and dust-free place. Ambient temperature during storage shall be 0 – 60°C. No operation and storage below dew point. Moisture must not exceed 60%. Igniters shall be protected from mechanical damages.

If the tube is longer than 1.5 m (approx. 60"), the igniter must be provided with a guide tube. This prevents the tube from bending too much. The end of the igniter tube should protrude at least 100 mm (approx. 4") from the end of the guide tube, if the ambient heat does not require otherwise.

The gap between carrier tube and igniter tube ought to be 5 mm (app. 0.2") or more.

In case of higher furnace temperatures additional cooling air may be supplied into the gap through a separate port.

The device has a limited service life. It is designed for appr. 250,000 start ups. For 50 start ups per day its lifetime would be about 10 years. This time decreases under bad conditions e.g. dust, high or low temperature, moisture, aggressive gases. The end user shall therefore take care that regular safety related maintenance checks are carried out at site.

When the appliance has reached the end of its lifetime it must be disposed of according to local regulations.

4. Flame Monitoring

The flame is monitored by a combined spark/ionisation electrode which must be doused into the flame. This flame rod is energized with an a.c. voltage. The burning flame creates a conductive connection to burner mass and acts as a rectifier for the small ionisation current. This d.c. signal is amplified in the flame monitor, which in turn switches a 90Vd.c. signal or an integrated flame relay (ZDA.. series only).

The internal resistance of the ionisation path is several MΩ. This high resistance requires good insulation for the electrodes and the connecting rods. Therefore, it is important to clean the insulators more often if the combustion air contains dust; avoid moisture.

The temperature of the ceramics must not exceed 500°C. Please see also chapter 'Technical Data; Maximum ambient temperatur'.

5. Construction According to Sectional Drawing

The igniter consist essentially of the junction box (item 1), the igniter outer tube with gas inlet flange and the inner tube with air inlet flange are fitted with 4 screws (4) with the transformer part. After loosening the screws (4) the gas and the air flange can be detached or rotated in 90° increments according to the location of the supply. The gas nozzle (14) is between the gas and air pipe. The igniter's flame is monitored by a combined spark/ ionisation electrode (15) which are connected by extensions (13) with the transformer part.

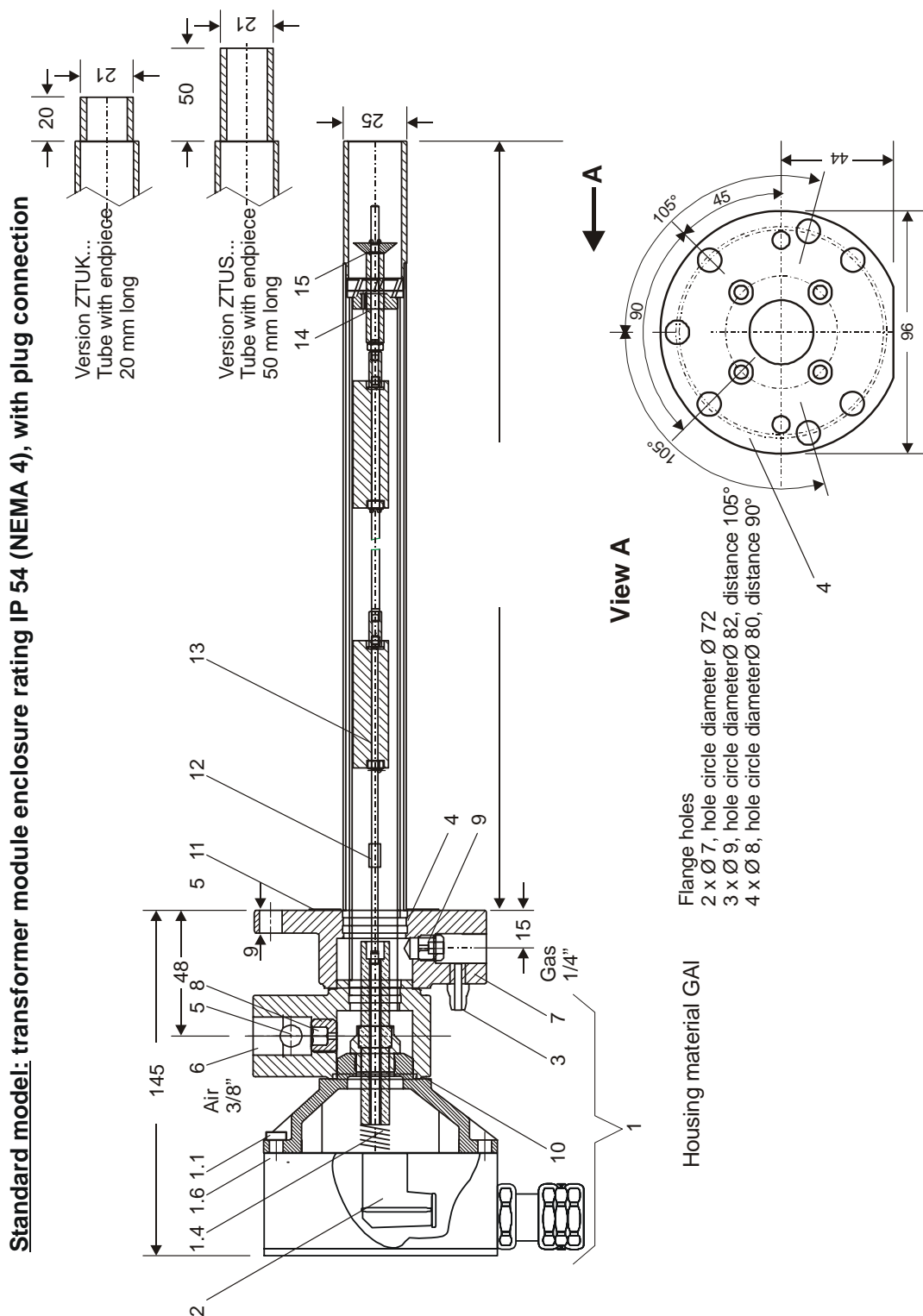

Igniter Sectional Drawing

6. Available Spare Parts and Wear and Tear Parts

Item.	Qty.	Description	Part Number	Voltages	Material	Remarks
1	1	Junction room	--		Cast aluminum	No spare part
2	1	High voltage plug	--		Bakelite	No spare part
3	1	Gas pressure test nipple	--		Brass * Stainless steel *	No spare part
4	4	Allen screw	--		Steel	No spare part
5	1	Air pressure test nipple			Brass * Stainless steel *	No spare part
6	1	air flange, with inner tube	Z1280Z_ _ _	Tube length given should be the same as that in the part number for the igniter	Stainless steel	Standard Can be rotated in increments of 90°
7	1	Gas flange with outer tube for ZGU...* ZGUS...* ZGUK...*	Z1300Z... Z1310Z Z1315Z...	Tube length given should be the same as that in the part number for the igniter	Stainless steel Stainless steel Stainless steel	Standard Special Special Can be rotated in increments of 90°
8	1	Restrictor for Air inlet Natural gas Manufactured gas Propane/Butane	Z142F600 Z142F650 Z142F650		Steel Steel Steel	Bores: Ø 6.0 mm Ø 6.5 mm Ø 6.5 mm
9	1	Restrictor for Gas Natural gas Manufactured gas Propane/Butane	Z141F180 Z141F280 Z141F150		Steel Steel Steel	Bores: Ø 1.8 mm Ø 2.8 mm Ø 1.5 mm
10	2	O-Ring	--			No spare part
11	1	Gasket	--			No spare part
12	*	Threaded bushing	A197F1			* Depends on the numbers of extensions
13	*	extension	Z169Z1 Z169Z2 Z169Z3	*Overall number depending on the tube length. Please state type of igniter in your order		
14	1	Gasnozzle for Natural gas and Propane/ Butane Manufactured gas	Z167F2 Z180F2		Stainless steel Stainless steel	Standard Standard
15	1	Ionisation and Spark electrode	Z168Z1			Subject to wear and tear

7. Accessories

The igniters can be connected to the following devices:

- Flame monitor D-IO 55-10
for intermittent operation
surface type unit
230 V 50/60 Hz
also available for 115 V 50/60 Hz
see also separate brochure
or with any other suitable flame monitor
- Burner control D-GF 55-10
for intermittent operation
surface type unit
230 V 50/60 Hz
also available for 115 V 50/60 Hz
see also separate brochure
or with any other suitable burner control for ionisation monitoring

Note: The flame signal cable should be installed separately from the spark cable to avoid interference.

8. Setting the Required Gas and Air Flow

The igniters operate in a pressure range of 20 mbarg \pm 2 mbar on the gas and air side, which may be measured using the **gas and air pressure test nipple (item 3 and 5/ sectional drawing)**. Open the test nipple by turning the inserted Allen screw anti clockwise by 1 ½ turns. Connect the hose with pressure gauge immediately (be aware of the pressure). After measurement close test nipple by turning clockwise immediately.

For easy pressure adjustment the igniter has to be fitted with ball cocks (to be ordered separately) that may be screwed directly into the gas and air port. Any furnace backpressures have to be compensated.

If the air pressure has been set correctly, the following will occur:

1. Immediate ignition
2. Good optical flame image
3. Flame length approx. 80 mm at a maximum capacity of 4 kW (approx. 14,000 BTU/hr)
unimpeded burn out

9. Maintenance and Alignment

These igniters do not require any special maintenance. They should, however, be checked periodically (e.g., every 3 months) for proper operation.

If the igniters are operated using air that contains dust, this check should be performed at shorter intervals, since electrically conductive dirt deposits or moisture on the ceramic insulators can lead to a fault in the igniter.

The intrinsic impedance of the ionisation path amounts to several M Ω . Such high resistance requires that the ceramic insulators be in perfect condition.

Performing Maintenance and Replacing Worn Parts

(please compare to the sectional drawing)

Igniter Tube (may be rotated in 90° increments)

After loosening the four screws (item 4) and Ionisation/Spark electrode (item 15) both tubes may be removed. Depending on the position of the air connection, the tube may be turned and tightened.

Caution: If tubes have to be replaced by new ones, remove the pressure-reducing restrictors, which are screwed in to the two threaded gas inlets, and put them into the threads of the new tubes.

Ionisation and Spark electrode

(subject to wear and tear, exempted from manufacturer's warranty)

Remove the igniter tubes see above. Loosen the Ionisation and Spark (15) from extension and replace it completely.

10. Electrical Function Test (without Flame) Using A10Z2 Test Diode

This test diode is employed to perform a purely electrical function test. Such a test should be carried out by authorized personnel only.

Caution: The gas valve must first be closed!

With the aid of the test diode A10Z2 (rectifier built in to a cable), may be simulated a flame signal to the flame monitor, once power is applied. The diode must be clamped to the ionisation electrode, the other end of the cable should make contact with burner mass (note the polarity!)

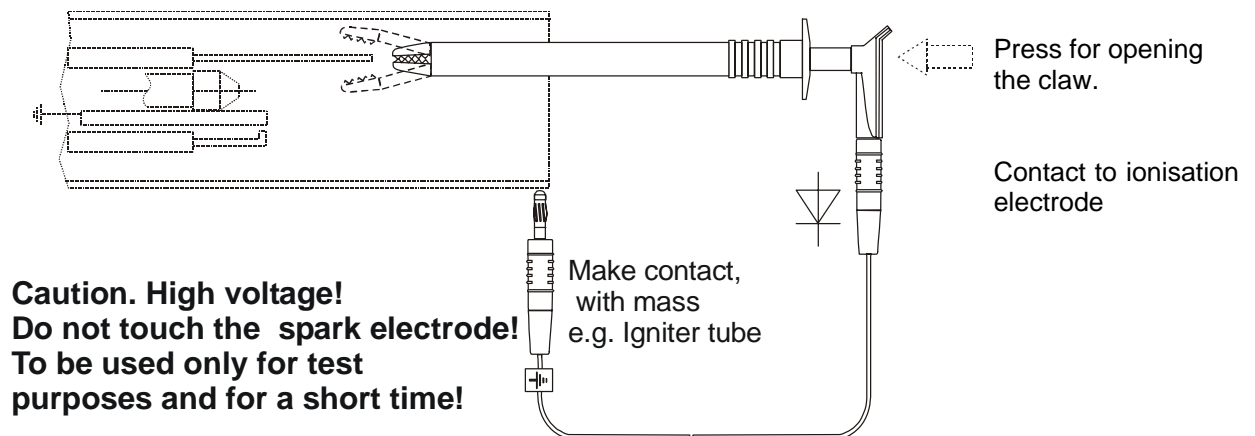

Once contact is made with the diode, the burner control should go into operation.

If there is no flame signal, the following should be checked:

- Is the supply voltage present on the burner control?
- Is the polarity of the test diode correct?
- Are the ceramic insulators damp, dirty or broken? If so, clean or replace.
Remedy: If so, clean or replace.

In case of spark problems please see chapter 'Trouble shooting'.

11. Gas- and Air-Regulating Components (to be ordered separately)

Gas: Ballofix Ball cock Z 845 Z1, D= 1/4"

Air: Ballofix Ball cock Z 845 Z2, D= 3/8"

Housing: Ms 58 brass
Gaskets: Teflon
Temperature range
-20° – +60°C (-4° – +140°F),
Pressure 300mbar max

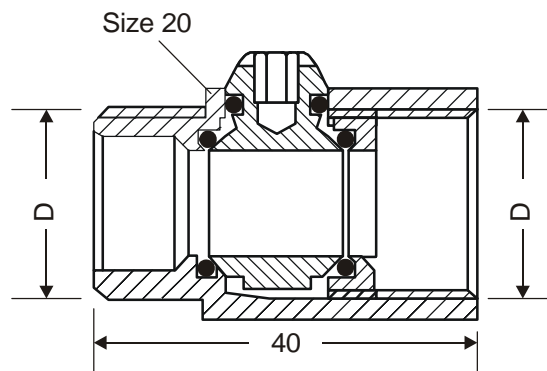

12. Troubleshooting

The following items have to be carried out step by step

12.1 Spark cannot be seen

Possible Causes:

- .1 Igniter has not been energized
- .2 Spark suppresses the ionisation signal.
(Visual check in dark surrounding with **fuel valves closed**.)



Caution: do not touch high voltage electrode.)

Possible Reasons/ Remedy

- .1.1 Remedy: Check wiring.
Check BMS.
- .2.1 Spark electrode internals has been burnt away
Remedy: replace electrode, clean igniter / burner internals and verify the correct spark gap.
- .2.2 Electrode distance to large or has a short circuit
Remedy: clean igniter / burner internals, replace worn parts and verify the correct spark gap of 2-3 mm.
- .2.3 Spark transformer faulty
Remedy: Replace spark transformer.
- .2.4 Tinder on the spark electrode or ground rod / bolt.
Remedy: clean igniter / burner internals, and remove layer with emery cloth.
- .2.5 Ceramic insulator is broken
(De-energize the igniter/ burner.
Remove outer tube.)
Remedy: Replace ceramic insulator.

12.2 Flame cannot be seen

Possible Causes:

- .1 No combustion air.
(Check pressure at test nipple).
- .2 No fuel
(Check pressure at test nipple).
- .3 Air/Fuel ratio not correct.
(Check fuel and air pressure at test nipple)

Possible Reasons / Remedy

- .1.1 Sleeves or valves are completely closed.
Flap or valve does not work.
- .1.2 Pipe is clogged.
- .2.1 Fuel pipe too long.
Remedy: Install valve close to Burner/ Igniter.
- .2.2 Fuel pipe inert with nitrogen.
Remedy: Start the igniter/ burner several times to get the inert gas removed and replaced by fuel.
- .2.3 Shut off valve is out of order.
Remedy: Replace fuel valve.
- .3.1 Check correct fuel and air pressure adjustment.
Use diagram values given in igniter/ burner manual.
- .3.2 Correct fuel type?
- .3.3 Clean combustion air?

12.3 Flame can be seen but no flame signal present after safety spark time has elapsed

Possible Causes:

- .1 No ionisation signal.
(Visual check with **fuel valves closed** and de-energized igniter/ burner.)
- .2 Igniter/ burner is wired to a Hegwein burner control:
Supply voltage is released simultaneously with operation voltage.
- .3 Igniter/ burner is wired to burner control of another make:
spark suppress the ionisation signal.
- .4 Burner/Igniter has been exposed to excessive temperature from combustion chamber during Burner/Igniter stand still. Ceramics are too hot, the insulation resistance has dropped to a value that is too low.
- .5 The setting of the fuel and air pressures at the burner/igniter are not correct. Flame root is not in the area of the ionisation electrode.
- .6 After failure correction of item1- 5 a flame signal is still not available.
If flame signal is still not reported though step 1 to 5 have been verified.

Possible Reasons / Remedy

- .1.1 Ionisation electrode has been burnt away.
Remedy: Replace electrode and verify the correct spark gap.
- .1.2 Ceramic insulator is broken.
Remedy: Replace insulator.
- .2.1 Operation voltage must lag supply voltage at least by 0.5 seconds.
- .3.1 Spark voltage must be shut off 0.5 seconds before spark safety time has elapsed.
- .4.1 Leave blower air fully on or in cooling stage while the burner/igniter is switched off.
- .5.1 Adjustment and correction of the corresponding devices.
Use diagram values as given in the available manual.
- .5.2 Flame is pushed out of the igniter/ burner mouth : Fuel or/ and air flow insufficient.
- .6.1 Remedy: Check complete wiring with test diode A10Z2.
See manual.

12.4 Shut off during operation

Possible Causes:

- .1 Varying back pressures or supply pressures cause the flame to trip.



Possible Reasons / remedy

- .1.1 Check pressure at the test nipples. Fluctuations require a differential pressure regulator on the air and fuel supply side.
- .1.2 Burner or igniter test should be carried out outside combustion chamber.
Local safety regulations must be observed.
- .2 Pilot flame is strongly influenced or when suffocated by the main flame.
 - .2.1 Remedy: Change igniter position
 - .2.2 Remedy: A more powerful burner/ igniter may be requested.

12.5 Automatic shut-down at start-up when a flame is reported before the spark fuel valve have been opened

Possible Causes:

- .1 Flame has not extinguished after the previous shut-down due to a leaking valve and is still present when system is restarted.

Possible Reasons / remedy

- .1.1 Remedy : Replace valve.

12.6 Electrical Malfunction

- .1 Burner control does not start

- .1.1 Remedy: Devices of a different make can cause trouble. See chapter.

In case of questions please give us the exact type designation as given on the nameplate.

13. Approvals



EG-Konformitätserklärung / *EC Declaration of Conformity*

Hersteller/ <i>Manufacturer</i>	Georg Hegwein GmbH & Co. KG
Anschrift/ <i>Address</i>	Am Boschwerk 7, D-70469 Stuttgart
Produktbezeichnung <i>Product description</i>	Gaszündbrenner Baureihe ZG... <i>Gas fired ignitors ZG...</i>

Die Zündbrenner sind für den industriellen Bereich vorgesehene Komponenten der Feuerung. Da sie keine elektrischen Zusatzbauteile beinhalten, können sie herstellerseitig keiner EMV-Prüfung unterzogen werden.

These burners are components for industrial combustion systems. As they are not fitted with integrated electrical parts the manufacturer cannot subject them to any EMC tests.

Die elektromagnetische Verträglichkeit kann nur nach bestimmungsgemäßem Einbau in eine Feuerung in Verbindung mit dem Zündtrafo und dem Zündkabel geprüft werden. Die Verantwortung liegt gemäß EMV-Richtlinie beim Errichter der Anlage.

The electromagnetic compatibility can only be proved after appropriate installation into a combustion system complete with the spark transformer and the ignition cable. As per EMC regulations, the erector has to take responsibility.

Die Störemission durch den hochfrequenten Zündfunken ist durch den Einbau in eine metallische Brennkammer und durch Verlegung der Kabel in einem metallisch/geerdeten Rohr bzw. Schlauch in der Regel unterbunden.

The interference emitted by the high frequency ignition spark, can in most cases be avoided by installing the burner into a metal combustion chamber and by laying the cables inside an earthed metal tube or hose.

Das bezeichnete Produkt stimmt mit den Vorschriften folgender europäischer Richtlinien überein, vorausgesetzt, dass es installiert, gewartet und entsprechend seiner Bestimmung eingesetzt wird. Die einschlägigen Vorschriften und Hinweise aus der Bedienungsanleitung sind zu beachten.

The described product complies with the following provisions of Council Directive, provided that it is installed, maintained and used in applications for which it was made, in accordance with relevant installation standards and manufacturer's instructions.

Richtlinie des Rates 90/396/EWG (Gasgeräte-Richtlinie)
Council Directive 90/396/EEC (Gas appliance directive)

Wir bestätigen die Konformität des oben bezeichneten Produkts mit folgenden Normen:
We confirm the conformity of the above mentioned product with the following standards:

EN 60730-1

\\PRIMERGV060\Vertrieb\Vorlagen\Formulare\Konformität\KONF_ZG_...doc

24.03.2004 08.04

Georg Hegwein GmbH + Co. KG
Am Boschwerk 7
D-70469 Stuttgart
Tel.: +49 711 13 57 88-0
Fax: +49 711 13 57 88-5

Banken: Deutsche Bank Stuttgart 9 212 200
BLZ 600 700 70
IBAN: DE04600700700921220000
SWIFT: DEUTDESS
Postbank Stuttgart 655 36-705
BLZ 600 100 70

Kommanditgesellschaft:
Stuttgart HRA 4951
USt-IdNr.:
DE 147 512 966
Steuernummer/Tax ID:
93153/01730

Persönlich haftende Gesellschafterin:
Hegwein GmbH
Stuttgart HRB 4303
Geschäftsführung:
Prof. Dr.-Ing. Peter Martin (Vorsitzender),
Dr.-Ing. Ulrich Greul

DURAG GROUP
*Solutions for Emission
and Combustion*
www.hegwein.de
e-mail: hegwein@durag.de



Aussteller
Issuer

Georg Hegweïn GmbH & Co. KG

Ort, Datum
Place, date

Stuttgart, 20.09.2003

Rechtsverbindliche Unterschrift
Legally binding signature

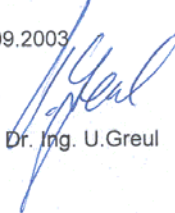
Dr.-Ing. U. Greul

VPRIMERGY060/Vertrieb/Vorlagen/Formulare/Konformität/KONF_ZG...doc

13.11.2003 15:31

Georg Hegweïn GmbH + Co. KG
Am Boschwerk 7
D-70469 Stuttgart
Tel.: +49 711 13 57 88-0
Fax: +49 711 13 57 88-5

Banken: Deutsche Bank Stuttgart 9 212 200
BLZ 600 700 70
IBAN: DE04600700700921220000
SWIFT: DEUTDESS
Postbank Stuttgart 655 36-705
BLZ 600 100 70

Kommanditgesellschaft:
Stuttgart HRA 4951
USt-IdNr.:
DE 147 512 966
Steuernummer/Tax ID:
93153/01730

Persönlich haftende Gesellschafterin:
Hegweïn GmbH
Stuttgart HRB 4303
Geschäftsführung:
Prof. Dr.-Ing. Peter Martin (Vorsitzender),
Dr.-Ing. Ulrich Greul

DURAG GROUP
*Solutions for Emission
and Combustion*
www.hegweïn.de
e-mail: hegweïn@durag.de