



Gas Igniter

**Maximum heat release: 2 kW (7,000 BTU/hr),
Compact design with spark transformer**

Model ZTF...

Ionisation controlled

Table of Contents

1. Part Numbering System	3
2. Technical Data	4
3. Storage and Installation Instructions and Lifetime	5
4. Flame Monitoring.....	5
6. Available Spare Parts and Wear and Tear Parts	7
7. Accessories	8
8. Electrical Connection.....	8
9. Setting the Required Gas and Air Flow.....	9
10. Maintenance and Alignment.....	9
11. Electrical Function Test (without Flame) Using A10Z2 Test Diode	10
12. Gas- and Air-Regulating Components (to be ordered separately)	11
13. Troubleshooting.....	11
14. Approvals	14

Note

- ***Please read this manual and adhere to it when making use of the device***
- ***Installation and maintenance procedures may only be carried out by authorized personnel***
- ***All local regulations and the prevailing codes of practice must be observed during installation.***
- ***Improper installation, alignment and maintenance, as well as modifications by the customer, can all lead to personal injury or property damage, as well as loss of warranty!***

1. Part Numbering System

The example below shows how the most important igniter information is incorporated into the part number:

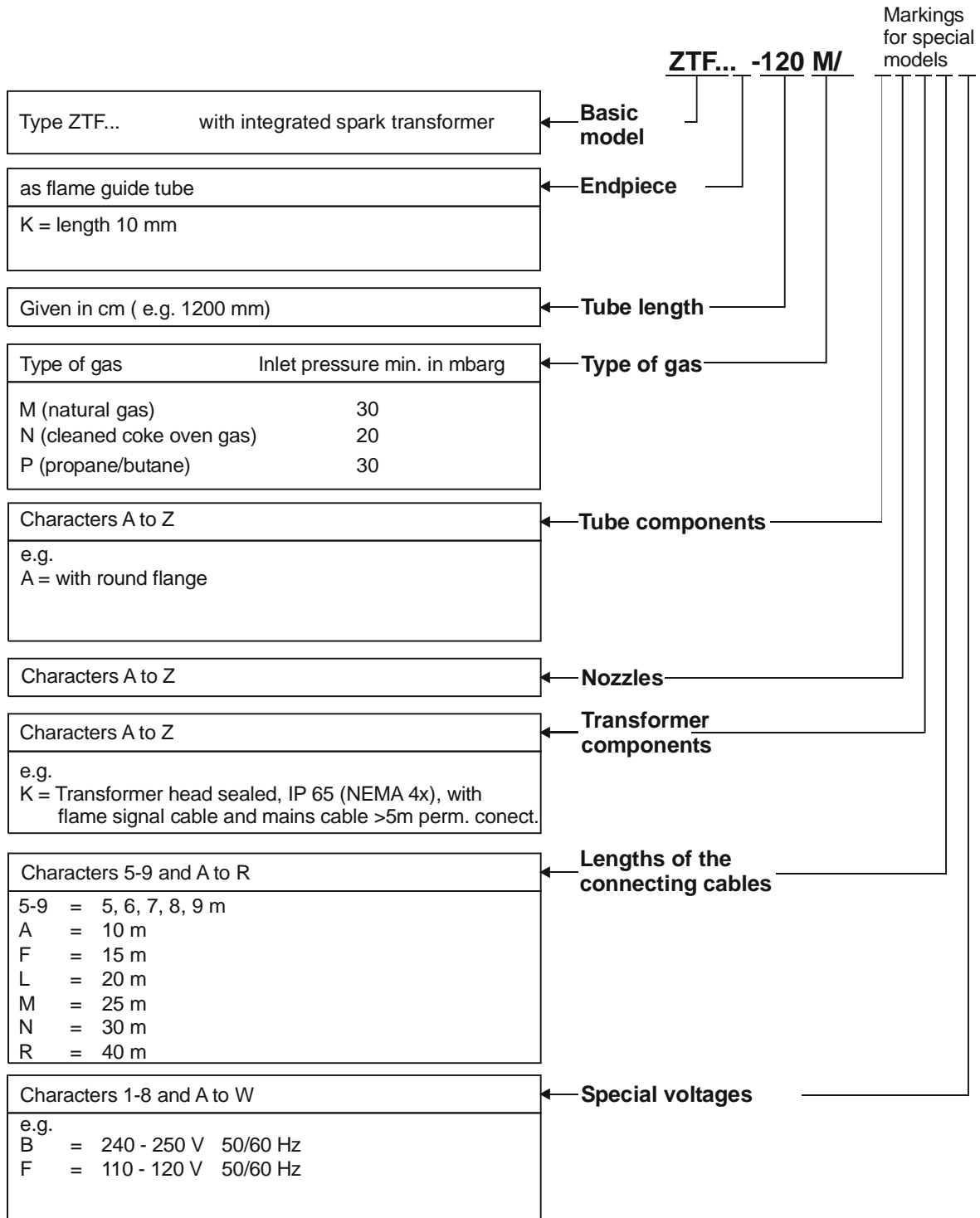

2. Technical Data

Burner Part

Heat release	max. 2 kW (7,000 BTU/hr)
Flame length.....	max. 80 mm (approx. 3")
Tube length.....	available in increments of 120 mm, length 120-3960 mm
Gas connection.....	1/4" (design pressure max. 10bar)
Gas flow, app.....	0.33 m ³ /h manufactured gas 0,15 m ³ /h natural gas 0,06 m ³ /h propane
Air connection.....	1/4"
Airflow	max. 1.5 m ³ /h
Maximum ambient temperature.....	igniter tube: 500°C (932°F); if temperature is higher, combustion air (20% min.) must be left on to serve as cooling air. At temperatures > 700°C (1292°F), additional cooling air must be supplied in the gap between the guide tube and igniter tube.
Maximum back pressure	200 mbarg inside the igniter housing

Transformer head

Spark transformer.....	(primary) 220/ 230 V 50/ 60 Hz (standard), or as specified in the part number (secondary) 5 kV to ground
Enclosure rating.....	IP 54 (NEMA 4) (standard) or IP 65 (NEMA 4x) (special)
Connection type.....	plug connection (IP 54 version), permanently sealed in flame signal and mains cable (IP 65 version)
Power consumption.....	spark transformer: 100 VA
Duty cycle	spark transformer: usually limited to 2 – 3 s by the burner control 15% duty cycle (cycle time 3 min. = 100 %) primary thermal winding protection
Ambient temperature.....	0°C to +60°C (+32°F to +140°F), where EC approval is required, otherwise, -20°C to +60°C (-4°F to +140°F) with special design IP 65
Monitoring with ionisation flame rod	See electrical connection (no flame monitor integrated)

May be connected to flame monitors and controllers on page 8.

3. Storage and Installation Instructions and Lifetime

Igniters are to be stored in a dry and dust-free place. Ambient temperature during storage shall be 0 – 60°C. No operation and storage below dew point. Moisture must not exceed 60%. Igniters shall be protected from mechanical damages.

If the tube is longer than 1.44 m (57"), the igniter must be provided with a guide tube. This prevents the tube from bending too much. The end of the igniter tube should protrude at least 50 mm (approx. 2") from the end of the guide tube, if the ambient heat does not require otherwise.

The gap between carrier tube and igniter tube ought to be 5 mm (app. 0.2") or more.

In case of higher furnace temperatures additional cooling air may be supplied into the gap through a separate port.

If intermediate tube length of igniter except 120 mm increments is necessary a compression fitting can be used. Please order it separately.

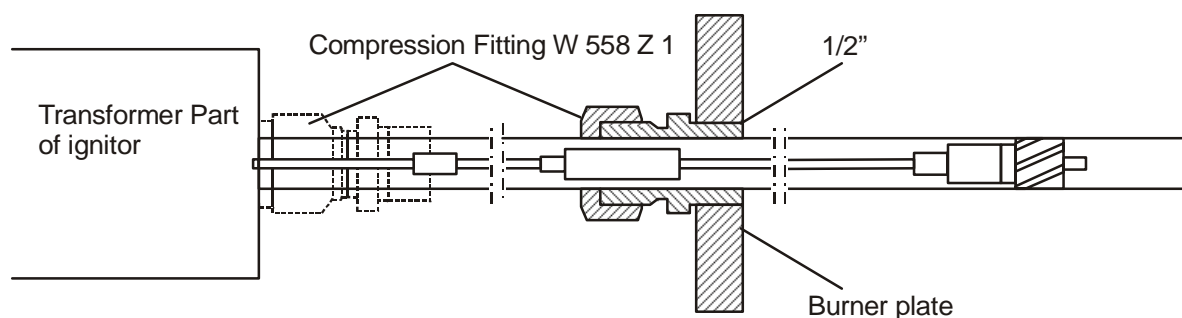

The device has a limited service life. It is designed for app. 250,000 start-ups. For 50 start-ups per day its lifetime would be about 10 years. This time decreases under bad conditions e.g. dust, high or low temperature, moisture, aggressive gases.

When the appliance has reached the end of its lifetime it must be disposed of according to local regulations.

4. Flame Monitoring

The flame is monitored by a combined spark/ionisation electrode which must be doused into the flame. This flame rod reports to a separate flame monitor which is energized by an a.c. voltage. The burning flame creates a conductive connection to burner mass and acts as a rectifier for the small ionisation current. This d.c. signal is amplified in the flame monitor, which in turn switches a signal.

The ionisation electrode and the ignition electrode are aligned according to the drawing on page 12. The electrode support ring is only available as one unit. The electrodes on the support ring are already bent and aligned.

The internal resistance of the ionisation path is several MΩ. This high resistance requires good insulation for the electrodes and the connecting rods. Therefore, it is important to clean the insulators more often if the combustion air contains dust; avoid moisture.

The temperature of the ceramics must not exceed 500°C. Please see also chapter 'Technical Data; Maximum ambient temperature'.

Standard model: transformer head enclosure rating IP 54 (NEMA 4), with plug connection

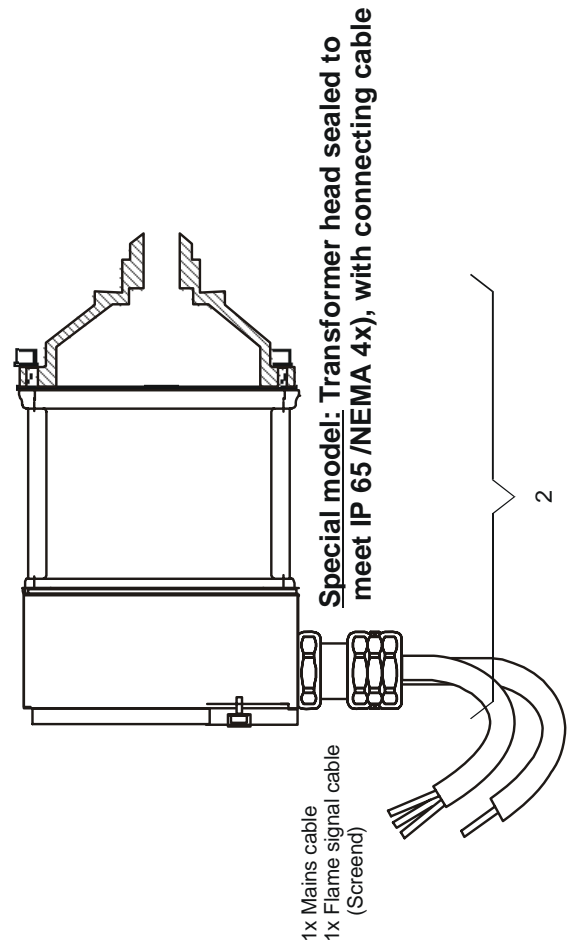
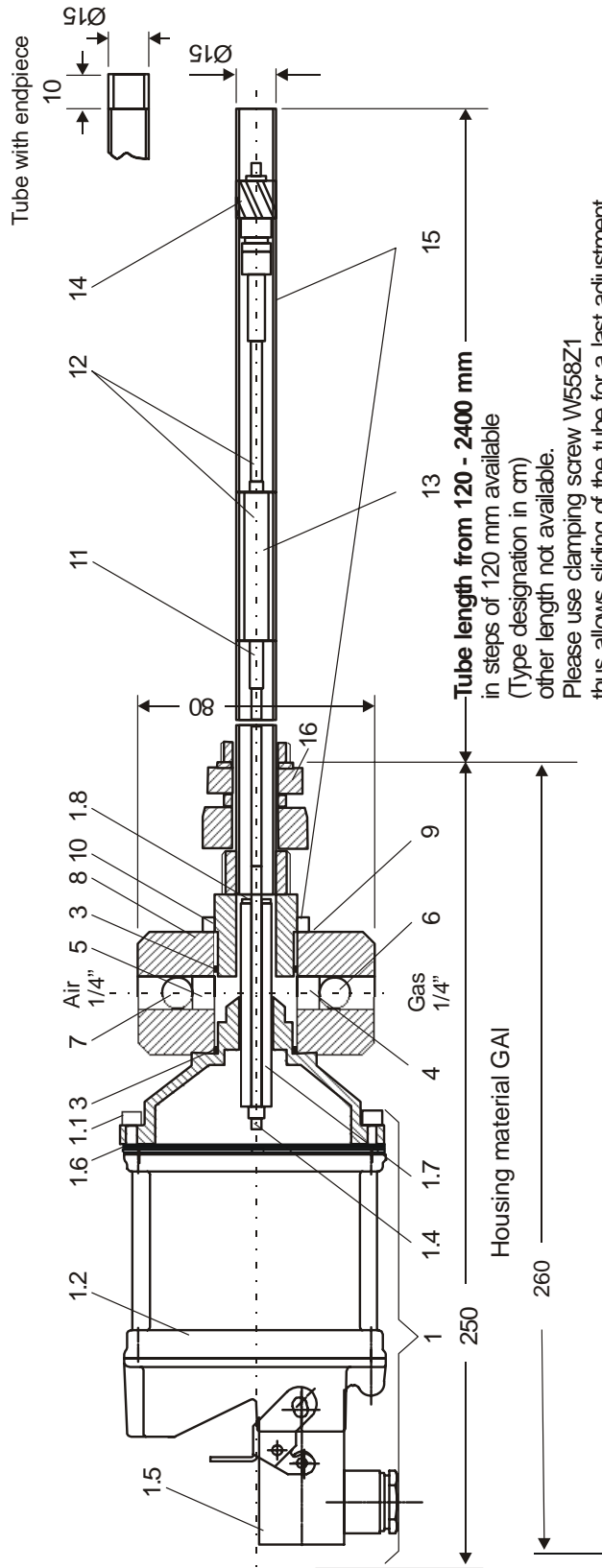

Igniter Sectional Drawing

6. Available Spare Parts and Wear and Tear Parts

Item.	Qty.	Description	Part Number	Voltages	Material	Remarks
1 1.1	1	Complete transformer head for ZTF...	Z150K7 Z150K7/00F Z150K7/00B	220/230 V 110/120 V 240/250 V	with housing, plug connection and gas flange	Standard model Special model Special model
1.1	2	Mounting screws			M 4	No spare part
1.2	1	Single spark transformer	Z550K230 Z550K115 Z550K00B	220/230 V 110-125 V 240/250 V	without housing	Standard model Special model Special model
1.5	1	90°plug with 2 M20x1.5 cable glands	A5Z1			10-pole, max. 2.5mm ² (AWG 14)
1.8	1	O-ring	W252F1		Viton	No spare part
2	1	Complete transformer head/ IP65 (NEMA 4X) for ZTF...	Z150K7_ _ _	Special model instead of Item 1: With supplementary information indicating cable length and voltage requirements (see <i>Part Numbering System</i> , p.3)		
3	2	O-ring	W676F1		Viton	No spare part
4	1	Restrictor for Gas inlet Natural gas Manufactured gas Propane/Butane	Z141F100 Z141F120 Z141F70			
5	1	Restrictor for Air inlet Natural gas Manufactured gas Propane/Butane	Z141F310 Z141F260 Z141F260			
6	1	Gas pressure test nipple	S53Z1		Brass Ms58	No spare part
7	1	Air pressure test nipple	S53Z1		Brass Ms58	No spare part
8	1	Gas/ Air housing	Z255Z1		Aluminium	
9	1	Locking Screw				No spare part
10	4	Allen screw				No spare part
11	*	Threaded bushing	A197F1			* in (12) included
12	*	Extensions with threaded bushing (11) and ceramic insulators (13)	Z159K1			* Depends on the length of igniter tube
13	*	Ceramic insulator	Z151F11			Included in (12)
14	1	Swirler nozzle with spark/ ionisation electr.	Z244K1		Stainless steel	Subject to wear and tear
15	1	Igniter tube with plug-in flange and threaded bushing ½" for ZTF...* ZTFK...*	Z256Z... Z256ZE...		Tube: stainless steel	* Type designation according length of igniter tube
16	1	Compression fitting	W558F1			

7. Accessories

The igniters can be connected to the following devices:

- Flame monitor D-IO 55-10
for intermittent operation
surface type unit
230 V 50/60 Hz
also available for 115 V 50/60 Hz
see also separate brochure
- Burner control D-GF 55-10
for intermittent operation
surface type unit
230 V 50/60 Hz
also available for 115 V 50/60 Hz
see also separate brochure

8. Electrical Connection

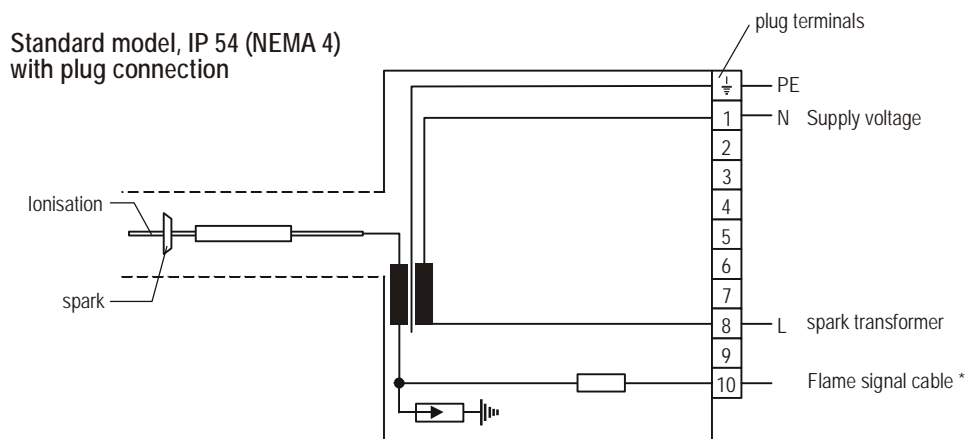

Special model enclosure rating IP 65 (NEMA 4x)
with mains cable and flame signal cable
transformer head sealed

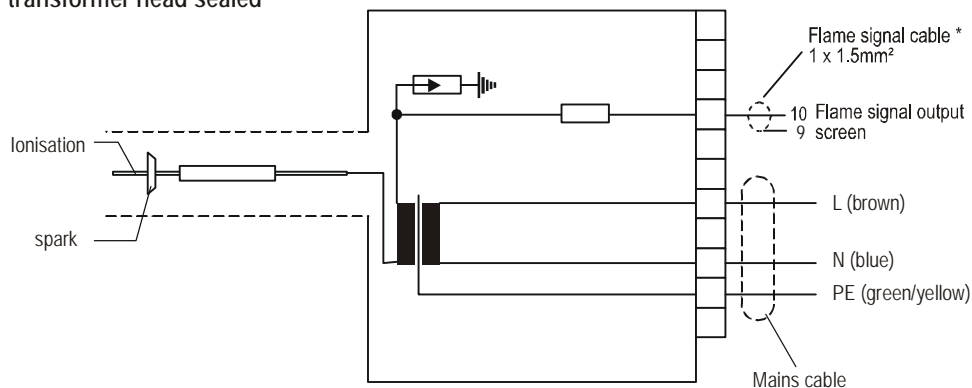

Power supply according to the name plate on the igniter

*) If wired to flame monitors or burner controls of Hegwein or another make: Adhere to relevant operating manual.

9. Setting the Required Gas and Air Flow

The igniters operate in a pressure range of 20 mbarg +/-2 mbar on the gas and air side, which may be measured using the **gas and air pressure test nipple (item 6 and 7/ sectional drawing)**. Open the test nipple by turning the inserted Allen screw anti clockwise by 1 ½ turns. Connect the hose with pressure gauge immediately (be aware of the pressure). After measurement close test nipple by turning clockwise immediately. For easy pressure adjustment the igniter has to be fitted with ball cocks (to be ordered separately) that may be screwed directly into the gas and air port. Any furnace backpressures have to be compensated.

If the air pressure has been set correctly, the following will occur:

1. Immediate ignition
2. Good optical flame image
3. Flame length approx. 80 mm at a maximum capacity of 2 kW (approx. 7,000 BTU/hr)
unimpeded burn out

10. Maintenance and Alignment

These igniters do not require any special maintenance. They should, however, be checked periodically (e.g., every 3 months) for proper operation.

If the igniters are operated using air that contains dust, this check should be performed at shorter intervals, since electrically conductive dirt deposits or moisture on the ceramic insulators can lead to a fault in the igniter.

The intrinsic impedance of the ionisation path amounts to several MΩ. Such high resistance requires that the ceramic insulators be in perfect condition.

Performing Maintenance and Replacing Worn Parts

(please compare to the sectional drawing)

Igniter Tube

After loosening the locking screw (item 9) the outer tube may be removed from Gas/Air flange. Depending on the position of the air connection, the tube may be turned and tightened.

Transformer head

The transformer head is completely interchangeable. To do so, the outer tubes must be detached see above and the Ionisation and Spark electrode (item 15) and the extensions (13) must be removed.

- The spark transformer may likewise be replaced individually. Loosen 4 screws and remove the housing.

Caution: When reassembling the igniter, be certain that the contact spring (item 1.4) is again in its correct position.

Ionisation and Spark electrode

(subject to wear and tear, exempted from manufacturer's warranty)

Remove the igniter tube see above. Loosen the Ionisation/ Spark electrode (14) from extension and replace it completely.

11. Electrical Function Test (without Flame) Using A10Z2 Test Diode

This test diode is employed to perform a purely electrical function test. Such a test should be carried out by authorized personnel only.

Caution: The gas valve must first be closed!

With the aid of the test diode A10Z2 (rectifier built in to a cable), may be simulated a flame signal to the flame monitor, once power is applied. The diode must be clamped to the ionisation electrode, the other end of the cable should make contact with burner mass (note the polarity!)

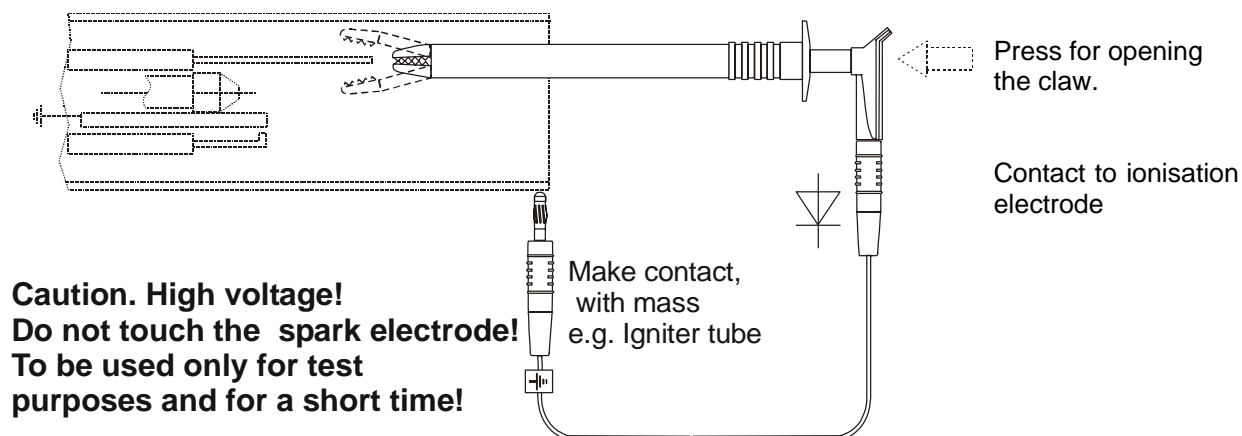

Once contact is made with the diode, the burner control should go into operation.

If there is no flame signal, the following should be checked:

- Is the supply voltage present on external flame monitor or burner control?
- Is the polarity of the test diode correct?
- Are the ceramic insulators damp, dirty or broken?
Remedy: If so, clean or replace. If necessary replace the transformer (item 1 or 2).

In case of spark problems please see chapter 'Trouble shooting'.

12. Gas- and Air-Regulating Components (to be ordered separately)

Gas and Air each:

Ballofix Ball cock Z 845 Z1

Housing: Ms 58 brass

Gaskets: Teflon

Temperature range

-20° – +60°C (-4° – +140°F),

Pressure 300mbar max

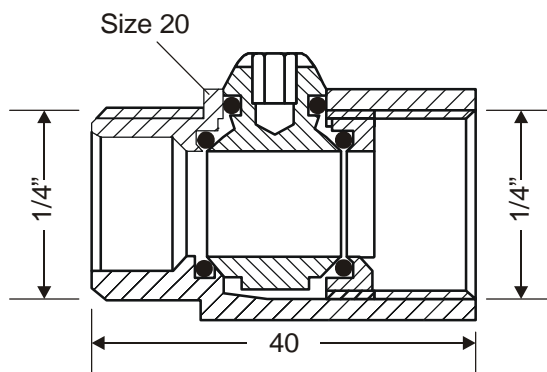

13. Troubleshooting

The following items have to be carried out step by step

13.1 Spark cannot be seen

Possible Causes:

- .1 Igniter has not been energized
- .2 Spark suppresses the ionisation signal.
(Visual check in dark surrounding with **fuel valves closed**.)



Caution: do not touch high voltage electrode.)

Possible Reasons/ Remedy

- .1.1 Remedy: Check wiring.
Check BMS.
- .2.1 Spark electrode internals has been burnt away
Remedy: replace electrode, clean igniter / burner internals and verify the correct spark gap.
- .2.2 Spark transformer faulty
Remedy: Replace spark transformer.
- .2.3 Tinder on the spark electrode or ground rod / bolt.
Remedy: clean igniter / burner internals, and remove layer with emery cloth.
- .2.4 Ceramic insulator is broken
(De-energize the igniter/ burner.
Remove outer tube.)
Remedy: Replace ceramic insulator.

13.2 Flame cannot be seen

Possible Causes:

- .1 No combustion air.
(Check pressure at test nipple).
- .2 No fuel
(Check pressure at test nipple).

Possible Reasons / Remedy

- .1.1 Sleeves or valves are completely closed.
Flap or valve does not work.
- .1.2 Pipe is clogged.
- .2.1 Fuel pipe too long.
Remedy: Install valve close to Burner/ Igniter.

- .2.2 Fuel pipe inert with nitrogen.
Remedy: Start the igniter/ burner several times to get the inert gas removed and replaced by fuel.
- .2.3 Shut off valve is out of order.
Remedy: Replace fuel valve.
- .3 Air/Fuel ratio not correct.
(Check fuel and air pressure at test nipple)
 - .3.1 Check correct fuel and air pressure adjustment.
Use diagram values given in igniter/ burner manual.
 - .3.2 Correct fuel type?
 - .3.3 Clean combustion air?

13.3 Flame can be seen but no flame signal present after safety spark time has elapsed

Possible Causes:

Possible Reasons / Remedy

- | | |
|---|--|
| <p>.1 No ionisation signal.
(Visual check with fuel valves closed and de-energized igniter/ burner.)</p> | <p>.1.1 Ionisation electrode has been burnt away.
Remedy: Replace electrode and verify the correct spark gap.</p> <p>.1.2 Ceramic insulator is broken.
Remedy: Replace insulator.</p> |
| <p>.2 Igniter/ burner is wired to a Hegwein burner control:
Supply voltage is released simultaneously with operation voltage.</p> | <p>.2.1 Operation voltage must lag supply voltage at least by 0.5 seconds.</p> |
| <p>.3 Igniter/ burner is wired to burner control of another make:
spark suppress the ionisation signal.</p> | <p>.3.1 Spark voltage must be shut off 0.5 seconds before spark safety time has elapsed.</p> |
| <p>.4 Burner/Igniter has been exposed to excessive temperature from combustion chamber during Burner/Igniter stand still. Ceramics are too hot, the insulation resistance has dropped to a value that is too low.</p> | <p>.4.1 Leave blower air fully on or in cooling stage while the burner/igniter is switched off.</p> |
| <p>.5 The setting of the fuel and air pressures at the burner/igniter are not correct. Flame root is not in the area of the ionisation electrode.</p> | <p>.5.1 Adjustment and correction of the corresponding devices.
Use diagram values as given in the available manual.</p> <p>.5.2 Flame is pushed out of the igniter/ burner mouth: Fuel or/ and air flow insufficient.</p> |
| <p>.6 After failure correction of item1- 5 a flame signal is still not available.
If flame signal is still not reported though step 1 to 5 have been verified.</p> | <p>.6.1 Remedy: Check complete wiring with test diode A10Z2.
See manual.</p> |

13.4 Shut off during operation

Possible Causes:

- .1 Varying backpressures or supply pressures cause the flame to trip.



Possible Reasons / remedy

- .1.1 Check pressure at the test nipples. Fluctuations require a differential pressure regulator on the air and fuel supply side.

- .1.2 Burner or igniter test should be carried out outside combustion chamber.

Local safety regulations must be observed.

- .2 Pilot flame is strongly influenced or when suffocated by the main flame.

- .2.1 Remedy: Change igniter position

- .2.2 Remedy: A more powerful burner/ igniter may be requested.

13.5 Automatic shut-down at start-up when a flame is reported before the spark fuel valve have been opened

Possible Causes:

- .1 Flame has not extinguished after the previous shutdown due to a leaking valve and is still present when system is restarted.

Possible Reasons / remedy

- .1.1 Remedy: Replace valve.

13.6 Electrical Malfunction

- .1 Burner control does not start

- .1.1 Remedy: Devices of a different make can cause trouble. See chapter.

In case of questions please give us the exact type designation as given on the nameplate.

14. Approvals



EG-Konformitätserklärung / *EC Declaration of Conformity*

Hersteller/ *Manufacturer* Georg Hegwein GmbH & Co. KG
 Anschrift/ *Address* Am Boschwerk 7, D-70469 Stuttgart
 Produktbezeichnung/ *Product description* Gas-Zündbrenner der Baureihe ZT...
Gas ignitors ZT...

Das bezeichnete Produkt stimmt mit den Vorschriften folgender europäischer Richtlinien überein, vorausgesetzt, dass es installiert, gewartet und entsprechend seiner Bestimmung eingesetzt wird. Die einschlägigen Vorschriften und Hinweise aus der Bedienungsanleitung sind zu beachten.

The described product complies with the following provisions of Council Directive, provided that it is installed, maintained and used in applications for which it was made, in accordance with relevant installation standards and manufacturer's instructions.

Richtlinie des Rates 90/396/EWG (Gasgeräte-Richtlinie)
Council Directive 90/396/EEC (Gas appliance directive)

Richtlinie des Rates 89/336/EWG (EMV-Richtlinie)
Council Directive 89/336/EEC (EMC Directive)

Richtlinie des Rates 73/23/EWG (Niederspannungsrichtlinie)
Council Directive 73/23/EEC (Low Voltage Directive)

Wir bestätigen die Konformität des oben bezeichneten Produkts mit folgenden Normen:

We confirm the conformity of the above mentioned product with the following standards:

EN 50081-1
 EN 50082-2
 EN 55011
 EN 60730-1

Aussteller/ *Issuer* Georg Hegwein GmbH & Co. KG

Ort, Datum/ *Place, date* Stuttgart, 20.09.2003

Rechtsverbindliche Unterschrift/ *Legally binding signature*

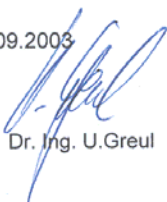
 Dr. Ing. U. Greul

\\PRIMERGY060\Vertrieb\Vorlagen\Formulare\Konformität\KONF_ZT.DOC

15.12.2003 15:50

Georg Hegwein GmbH + Co. KG
 Am Boschwerk 7
 D-70469 Stuttgart
 Tel.: +49 711 13 57 88-0
 Fax: +49 711 13 57 88-5

Banken: Deutsche Bank Stuttgart 9 212 200
 BLZ 600 700 70
 IBAN: DE04600700700921220000
 SWIFT: DEUTDE33
 Postbank Stuttgart 655 36-705
 BLZ 600 100 70

Kommanditgesellschaft:
 Stuttgart HRA 4951
 USt-IdNr.:
 DE 147 512 966
 Steuernummer/Tax ID:
 93153/01730

Persönlich haftende Gesellschafterin:
 Hegwein GmbH
 Stuttgart HRB 4303
 Geschäftsführung:
 Prof. Dr.-Ing. Peter Martin (Vorsitzender),
 Dr.-Ing. Ulrich Greul

DURAG GROUP
*Solutions for Emission
 and Combustion*
 www.hegwein.de
 e-mail: hegwein@durag.de