



Gas Burner

Ionisation monitored,
Max. Heat Release 35 kW (120,000 BTU)
Compact design with ignition transformer and burner control,
Quick-disconnect gas lance design
(no disconnection of gas- and air inlets required)

Type **BR0** ...
for intermittend operation

Type **BD0** ...
for continuous operation

Table of contents

1. Part Numbering System	3
2. Technical Data	4
3. Design According to Dimensional Drawing.....	4
4. Removing the Gas Lance (Quick Disconnect).....	6
5. Flame monitoring	6
6. Storage and Installation Instructions and Lifetime	6
7. Electrical Connection	7
8. Functional Description of Burner Control	7
9. Program Sequence for Z725K2 and Z725K3	8
10. p, V – Gas/Air Diagrams	8
11. Parts List	9
12. Electrical Function Test (without Flame).....	10
13. Maintenance.....	11
14. Troubleshooting	12
15. Approvals	15

Note

- ***Please read this manual and adhere to it when making use of the device***
- ***Installation and maintenance procedures may only be carried out by authorized personnel***
- ***All local regulations and the prevailing codes of practice must be observed during installation.***
- ***Improper installation, alignment and maintenance, as well as modifications by the customer, can all lead to personal injury or property damage, as well as loss of warranty!***

1. Part Numbering System

The example below shows how the most important burner information is incorporated into the part number:

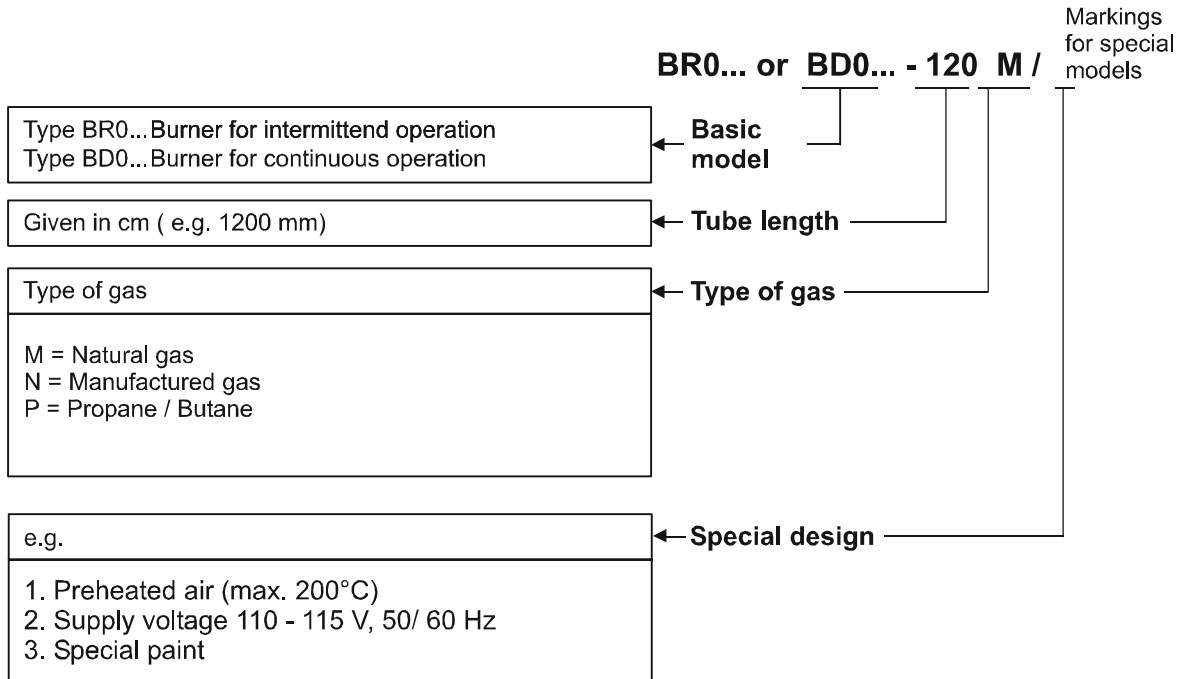

2. Technical Data

Burner Portion

Fuel.....	Gases, according to DVGW spec. sheet G 260
Heat release	max. 35 kW (120,000 BTU)
Flame length.....	max. 300 mm (approx. 12")
Operating mode.....	1-, 2-stage or modulated
Turn-down ratio	10 : 1 (required supply pressures \geq 50 mbar)
Burner tube	\varnothing 50 mm, length see page 5
Gas connection	3/4", variable (design pressure max. 300 mbar)
Air connection.....	2" from top, may be rotated in increments of 90°
Combustion air	max. 80 °C
Maximum ambient temperature	burner tube: If furnace temperatures exceed 500 °C and the burner is shut down, 20 % of the combustion air supply should be left on as a source of cooling air
Maximum back pressure	200 mbar inside the Burner housing

Burner Control approved as per DIN EN 298 for intermittent or continuous operation

Prepurge Time.....	determined on site by furnace control
Safety Time	3 seconds for flame establishment
Shut-off Time	< 1 second after flame failure
Break prior to restart.....	> 3 seconds
Connection Voltage	220/ 230 V, 50/ 60 Hz, fuse protection 6 A (provided by customer)
Electrical connection	Plug connection
Flame Signal (test jacks)	Ionisation current \geq 10 μ A
Ignition	5 kV to ground (max. 2,5 sec.within safety time)
Power Consumption	Ignition transformer 100 VA, Flame monitor 10 VA
Contact Load, terminal 8	max. 2 A ohm.
Contact Load, terminal 9	max. 2 A ohm.
	Number of operations: max. 10 ⁶
	Switch frequency: max. 10/min.
Ambient Temperature	0 °C to + 60 °C
Enclosure Rating	IP 54 (NEMA 4)

3. Design According to Dimensional Drawing

The burner basically consists of the burner head with transformer and burner control (item 1), the burner tube with air and mounting flanges (item 6), the gas tube (item 9), the slotted disc (item 11), as well as the electrode support ring (item 10). The burner tube with the connection for the air supply is threaded onto the gas flange, and may be taken off or rotated 90° (if necessary due to the location of the air connection) after removing the 4 screws (item 4).

The electrode support ring (item 10) is mounted to the end of the gas tube. The ionization electrode and the ignition electrode are lengthened using connecting rods (item 8). These rods are led through 2 ceramic insulators into the connection housing. With longer burners, they are supported by intermediate support rings (item 7) in intervals of 300 mm.

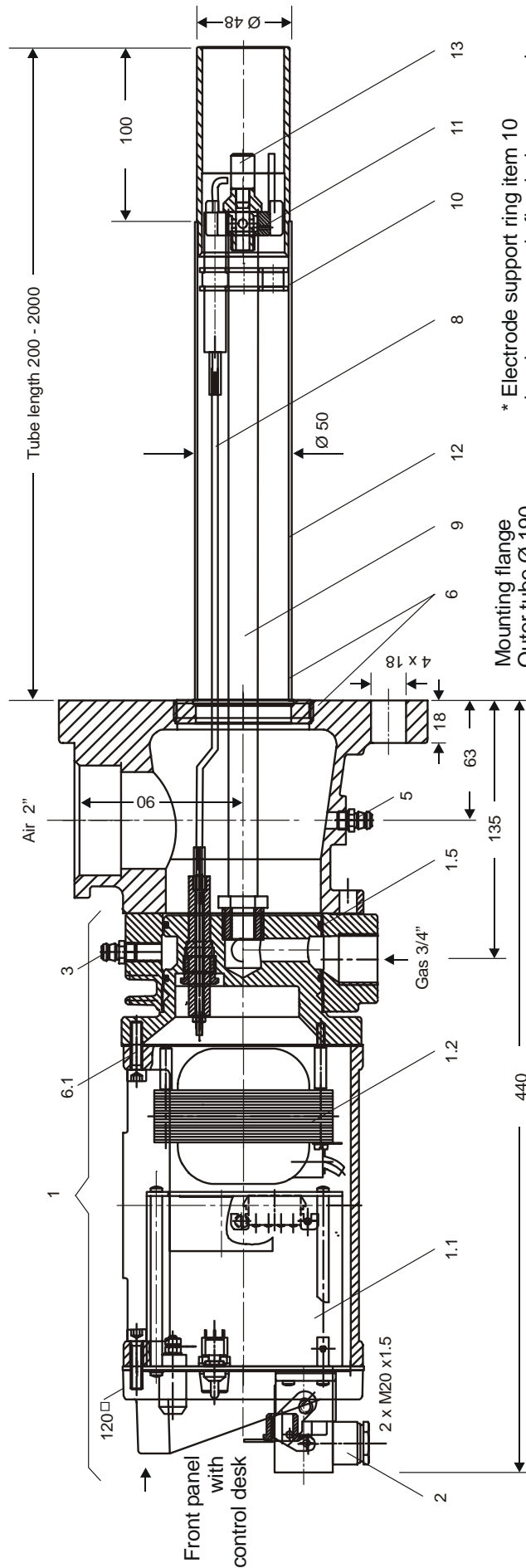

* Electrode support ring item 10 has been correctly fixed when ceramic insulators ends at a distance of 5 mm in slotted disc item 11. For better understanding the electrodes are shown in top elevation, i.e. revolved by 90° on the burner axis.

Adjustment see page 9.

Mounting flange
Outer tube Ø 190,
Bolt circle Ø 150

All dimensions in mm

Burner Sectional Drawing

4. Removing the Gas Lance (Quick Disconnect)

After removing the two screws (page 5, item 6.1), the entire gas lance and burner head may be withdrawn from the burner tube without disconnecting the gas and air connectors. The burner insert may thus be easily inspected or replaced during operation.

Attention: Before removing lance decrease Combustion chamber overpressure.

Burner assembly

When inserting the gas lance back into burner tube, be careful that O-rings (item 1.5) are not damaged. Fasten the burner lance using the two screws (item 6.1).

5. Flame monitoring

The flame is monitored by an ionisation electrode which must be doused into the flame. This flame rod is energized with an a.c. voltage. The burning flame creates a conductive connection to burner mass and acts as a rectifier for the small ionisation current. This d.c. signal is amplified in the flame monitor.

The ionisation electrode and the ignition electrode are aligned according to the drawing on page 5. The electrode support ring is only available as one unit. The electrodes on the support ring are already bent and aligned.

The internal resistance of the ionisation path is several M Ω . This high resistance requires good insulation for the electrodes and the connecting rods. Therefore, it is important to clean the insulators more often if the combustion air contains dust; avoid moisture.

The temperature of the ceramics must not exceed 500°C. Please see also chapter 'Technical Data; Maximum ambient temperature'.

6. Storage and Installation Instructions and Lifetime

Burners are to be stored in a dry and dust-free place. Ambient temperature during storage shall be 0 – 60°C. No operation and storage below dew point. Moisture must not exceed 60%. Burners shall be protected from mechanical damages.

If the tube is longer than 3 m (approx. 118"), the burner must be provided with a guide tube. This prevents the tube from bending too much. The end of the burner tube should protrude at least 150 mm (approx. 6") from the end of the guide tube, if the ambient heat does not require otherwise.

The gap between carrier tube and burner tube ought to be 5 mm (app. 0,2") or more.

In case of higher furnace temperatures additional cooling air may be supplied into the gap through a separate port.

The device has a limited service live. It is designed for appr. 250,000 start ups. For 50 start ups per day its lifetime would be about 10 years. This time decreases under bad conditions e.g. dust, high or low temperature, moisture, aggressive gases. The end user shall therefore take care that regular safety related maintenance checks are carried out at site.

When the appliance has reached the end of its lifetime it must be disposed of according to local regulations.

7. Electrical Connection

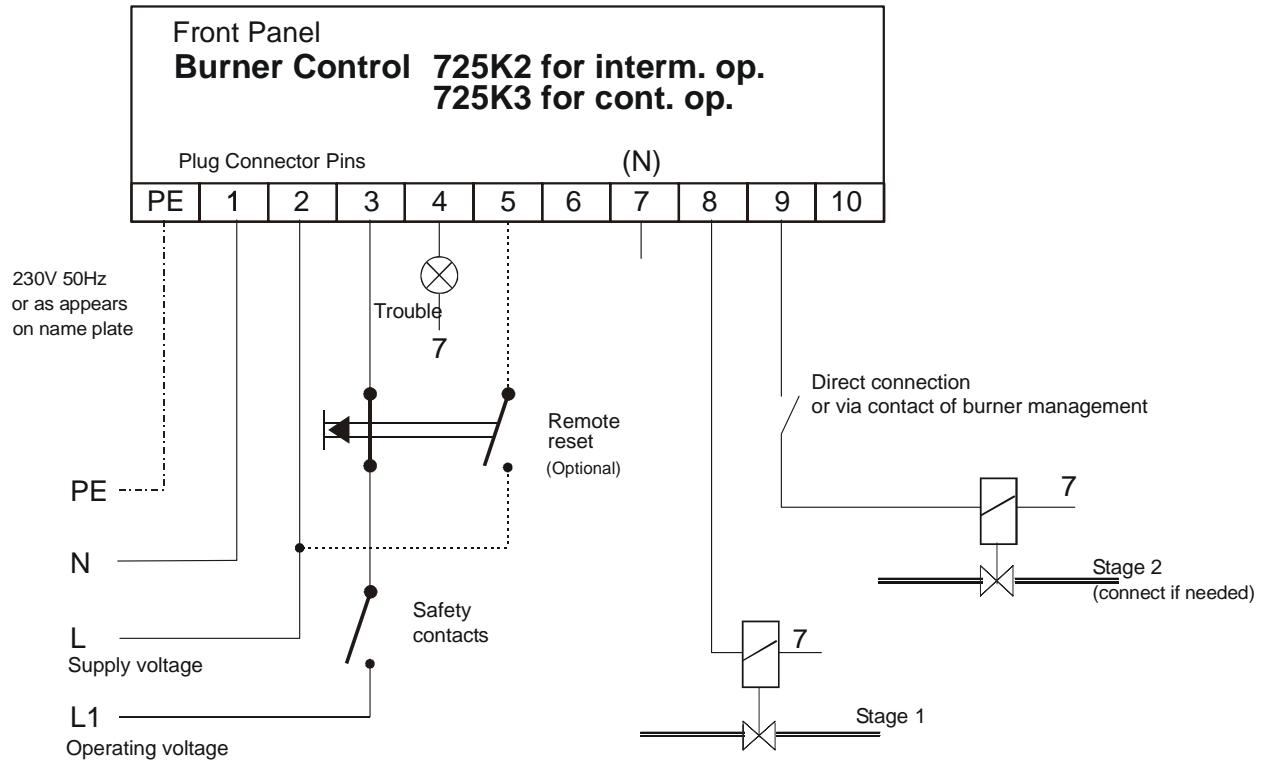

8. Functional Description of Burner Control

Front panel

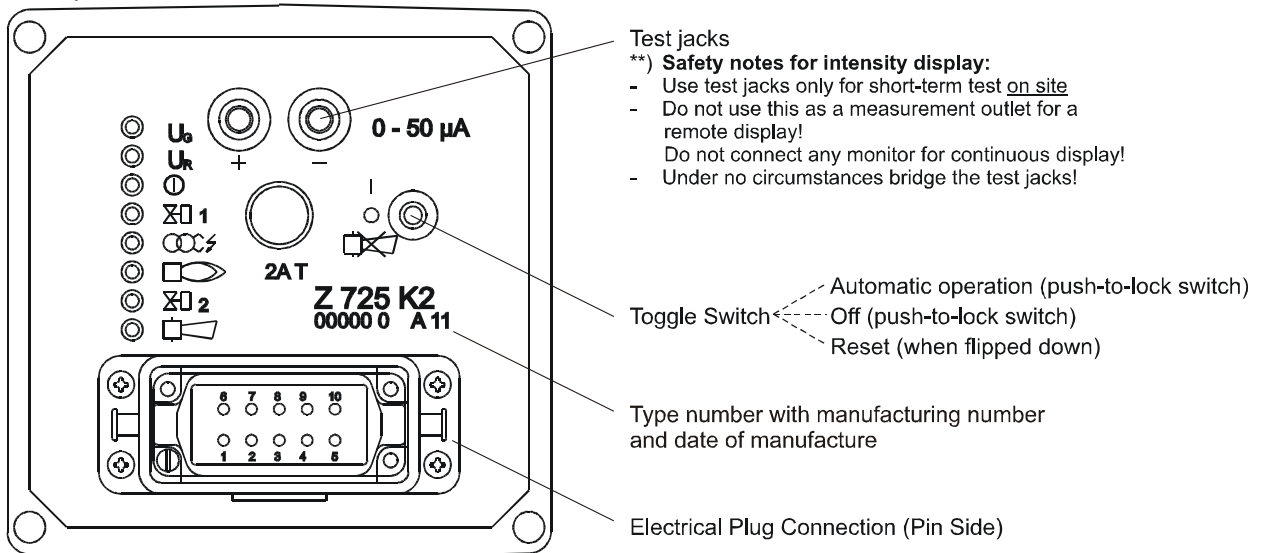

After supplying voltage to pin 2, the system is ready for operation (LED U_G is illuminated). First flip the „Automatic Operation“ toggle switch to the „I“ position. The operating or control voltage can now be supplied to pin 3 (LED U_R is illuminated). Pin 8 will automatically receive voltage, valve 1 will open (LED Valve 1 is illuminated) and ignition occurs with the illumination of the LED. A flame acknowledgment signal will be issued (yellow LED is illuminated) after a maximum of 3 seconds given correct flame production. The burner control switches to the operational mode, valve 2 (or a sequential switch) is released via pin 9, and the valve 2 LED will be illuminated.

By flipping the toggle switch down, the burner control may be reset after an unsuccessful start or failure of the flame signal (red LED illuminated). Afterward, the burner can be restarted.

A remote reset is also possible. If a button is available for this purpose, the contacts must be connected to pins 3 and 5.

9. Program Sequence for Z725K2 and Z725K3

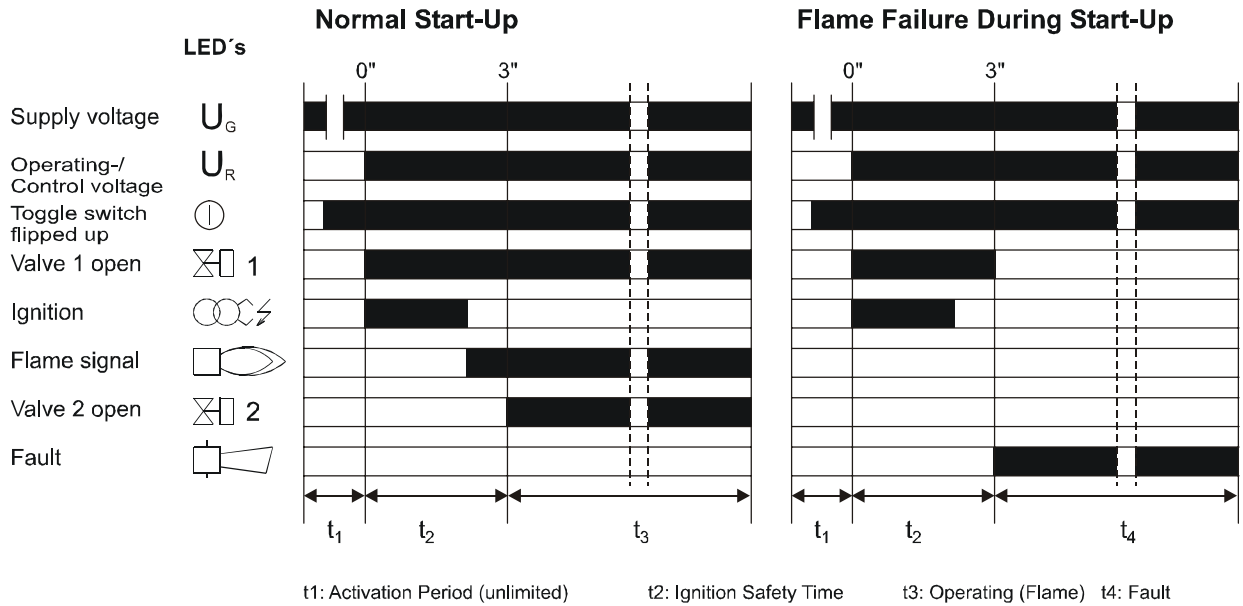

10. p, V – Gas/Air Diagrams

The pressures supplied below do not account for furnace pressure. The flow pressures are to be measured at each test nipple. The air pressure test nipple (item 5) is located across from the air inlet and the gas test nipple (item 3) is across from the gas inlet. Open the test nipple by turning the inserted Allen screw anti clockwise by 1 ½ turns. Connect the hose with pressure gauge immediately (be aware of the pressure). After measurement close test nipple by turning clockwise immediately.

Heat release

town gas	ca.	5 kWh/ m ³
natural gas	ca.	10 kWh/ m ³
propane	ca.	26 kWh/ m ³
propane/ butane	ca.	30 kWh/ m ³

Required quantity of air in m³/h per m³/h Gas for air factor n=1,1

Factor for	town gas	5	m ³ /h
	natural gas	10	m ³ /h
	propane	26	m ³ /h
	propane/ butane	30	m ³ /h

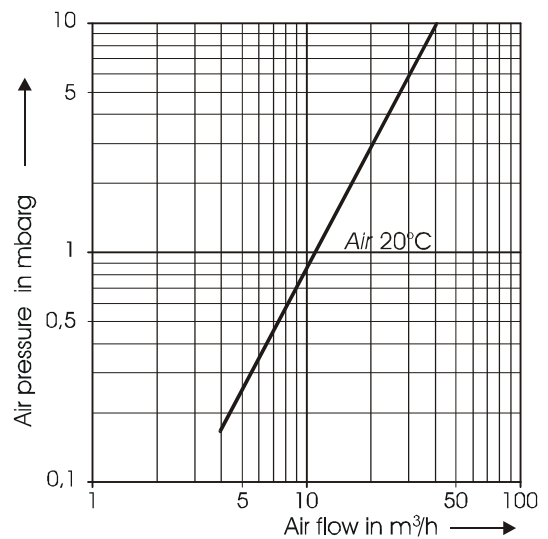
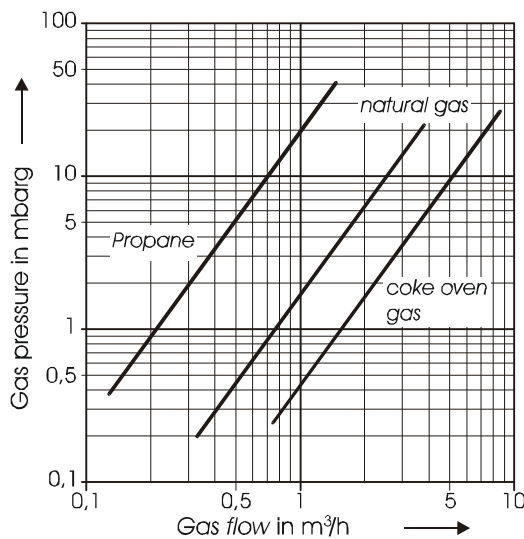

The exact setting for the burner should be determined via flue gas measurements, with a residual oxygen content of 3 - 5 % and CO value near zero.

The graphs shown are based on average values regarding gas density, gas composition, calorific value, burner version and burner tube length as well as optimised surrounding (unimpeded burn out and no back pressure in combustion chamber). The supply pressure derived from the graphs should therefore be regarded as guide numbers only. The actually required values can deviate, depending on site conditions.

11. Available Spare Parts and Wear and Tear Parts

Item	Qty.	Description	Part-No.	Material
1	1	Ignition transformer and burner control incl. ionisation flame monitor in cast housing with gas flange	BR.. BD.. Z 510 K 2 Z 510 K 3	Housing cast aluminum GAl
1.1	1	Burner control with front plate	BR.. BD.. Z 725 K 2 Z 725 K 3	fuse 2 Amp. slow bl. P-No. ES2000TR5T
1.2	1	Single ignition transformer	Z 546 K 230E2	
1.4	1 1	Gaskets Gaskets	Z 748 F 1 Z 748 F 20	
1.5	2	Gaskets O-ring	W 665 FV001	
2	1	Plug with 2 cable glands, M20x1.5	A 5 Z 1	10-pole max. 2,5 mm ²
3	1	Gas pressure test nipple	--	No spare part
4	4	Allen screws	--	No spare part
5	1	Air pressure test nipple	--	No spare part
6	1	Burner tube with welded in mixing chamber with mounting flange Z 729 F 2 and air port	Z 1390 Z*....	Flange cast aluminum Tube stainless steel
6.1	2	Allen screws	--	No spare part
7	x	Intermediate support ring with 2 ceramic insulators Z 545 F 11	Z 960 K 144	*Qty. required depends on tube length: 3 rings per meter
8	2	Connecting rods Ø 3mm	--	Stainless steel No spare part
9	1	Gas tube Ø 21,3 x 2,65	Z 521 F...E	stainless steel No spare part
10	1	Electrode support ring with 2 ceramic insulators and 2 electrodes	Z 960 K 150	Subject to wear and tear
11	1	Slotted discs: Natural gas Propane/Butane	-- --	Stainless steel Stainless steel No spare part
13	1	Bolt	Z 685 F 3	Stainless steel

12. Electrical Function Test (without Flame)

This test diode is employed to perform a purely electrical function test. Such a test should be carried out by authorized personnel only.

Caution: The gas valve must first be closed!

With the aid of the test diode A10Z2 (rectifier built in to a cable), may be simulated a flame signal to the flame monitor, once power is applied. The diode must be clamped to the ionisation electrode, the other end of the cable should make contact with burner mass (note the polarity!).

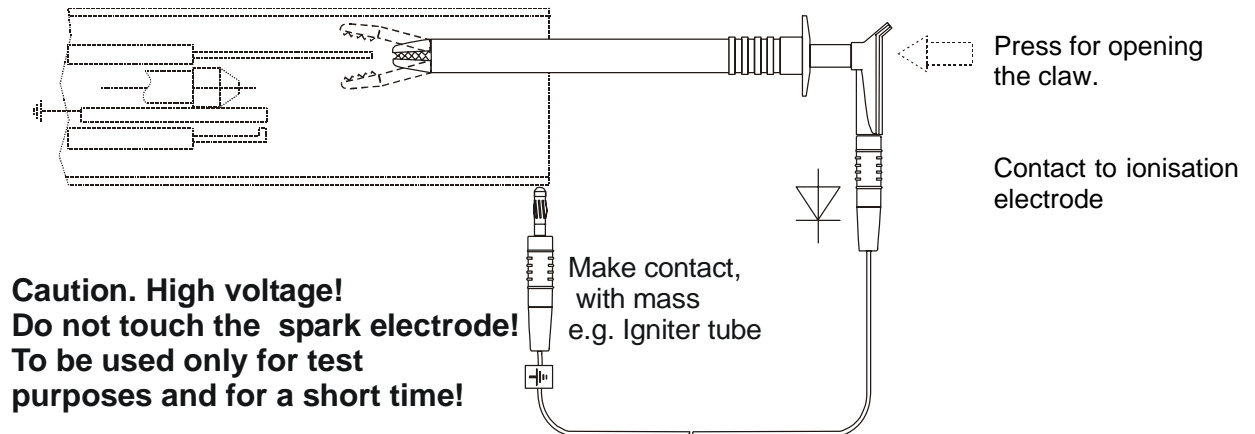

If still no flame signal is generated, please check:

- Is the burner control correctly wired for the supply and operating voltages?
- Has the polarity of the test diode been observed?
- Is the diode in good condition?
- Are the ionization electrode and its ceramic insulators in good condition?

If no flame signal can be generated, replaced the complete burner control.

13. Maintenance

The units do not require special maintenance. However they should be tested for proper function at certain intervals (for instance after 3 months). Keep attention to mechanical lifetime of burner control.

This test has to be carried out in shorter periods if the burners are operated with dusty combustion air since electrically conductive dirt deposits or moisture on the ceramic insulators of the burners might result in a breakdown of service. The ionisation circuit has an inner resistance of several M Ω . Undamaged and clean ceramic insulators are therefore a necessary prerequisite.

Replacement Parts (please see dimensional drawing on page 5)

1. Burner Head

Burner control and ignition transformer can be replaced individually.

2. Burner Tube

After removing the four screws (item 4) on the gas flange, the entire gas tube may be removed.

3. Electrode Support Ring (subject to wear and tear, exempted from manufacturer´s warranty)

Remove the outer tube. Unscrew the bolt (item 13) and remove the slotted disc. Loosen the clamping screw on the support ring and slide the support ring off the gas tube. Slide on the new support ring (with unbent electrodes), insert the connecting rods into the sockets on the ring, and tighten the clamping screw (Position see page 5).

The ionization electrode remains unbent, and should be cut off even with the end of the bolt (item 13). Cut the ignition electrode to length and bend 90° about halfway up toward the bolt, leaving a gap of approx. 2 - 3 mm.

4. Intermediate Support Rings (only for tube lengths 600 mm or longer)

Remove the outer tube and electrode support ring. Loosen the clamping screw on the support ring. The ring may then be slid off the gas tube. Slide the new support ring onto the gas tube and insert the connecting rods into the insulators. The intermediate support rings should be spaced 300 mm from one another. The electrode support rings then slid onto the gas tube and the ends of the connecting rods are inserted again into the sockets. All clamping screws are then tightened. One must observe, however, that the connecting rods do not get twisted.

14. Troubleshooting

The following items have to be carried out step by step

14.1 Spark cannot be seen

Possible Causes:

- .1 Burner/ Ignitor has not been energized
- .2 Spark suppresses the ionisation signal.
(Visual check in dark surrounding with **fuel valves closed**.)



Caution: do not touch high voltage electrode.)

Possible Reasons/ Remedy

- .1.1 Remedy: Check wiring.
Check BMS.
- .2.1 Ignition electrode internals has been burnt away
Remedy: replace electrode, clean ignitor / burner internals and verify the correct spark gap.
- .2.2 Electrode distance too large or has a short circuit
Remedy: clean ignitor / burner internals, replace worn parts and verify the correct spark gap of 2-3 mm.
- .2.3 Spark transformer faulty
Remedy: Replace spark transformer.
- .2.4 Tinder on the ignition electrode or ground rod / bolt.
Remedy: clean ignitor / burner internals, and remove layer with emery cloth.
- .2.5 Ceramic insulator is broken
(De-energize the ignitor/ burner.
Remove outer tube.)
Remedy: Replace ceramic insulator or better complete electrode support ring.

14.2 Flame cannot be seen

Possible Causes:

- .1 No combustion air.
(Check pressure at test nipple).
- .2 No fuel
(Check pressure at test nipple).
- .3 Air/Fuel ratio not correct.
(Check fuel and air pressure at test nipple)

Possible Reasons / Remedy

- .1.1 Sleeves or valves are completely closed.
Flap or valve does not work.
- .1.2 Pipe is clogged.
- .2.1 Fuel pipe too long.
Remedy: Install valve close to Burner/ Ignitor.
- .2.2 Fuel pipe inert with nitrogen.
Remedy: Start the ignitor/ burner several times to get the inert gas removed and replaced by fuel.
- .2.3 Shut off valve is out of order.
Remedy: Replace fuel valve.
- .3.1 Check correct fuel and air pressure adjustment.
Use diagram values given in ignitor/ burner manual.
- .3.2 Correct fuel type?

.3.3 Clean combustion air?

14.3 Flame can be seen but no flame signal present after safety ignition time has elapsed

Possible Causes:

- .1 No ionisation signal.
(Visual check with **fuel valves closed** and de-energized ignitor/ burner.)
- .2 Burner/Ignitor has been exposed to excessive temperature from combustion chamber during Burner/Ignitor stand still. Ceramics are too hot, the insulation resistance has dropped to a value that is too low.
- .3 The setting of the fuel and air pressures at the burner/ignitor are not correct. Flame root is not in the area of the ionisation electrode.
- .4 After failure correction of item1- 3 a flame signal is still not available. If flame signal is still not reported though step 1 to 5 have been verified.

Possible Reasons / Remedy

- .1.1 Ionisation electrode has been burnt away.
Remedy: Replace electrode and verify the correct spark gap.
- .1.2 Remedy: Replace ceramic insulator or better complete electrode support ring.
- .2.1 Leave blower air fully on or in cooling stage while the burner/ignitor is switched off.
- .3.1 Adjustment and correction of the corresponding devices. Use diagram values as given in the available manual.
- .3.2 Flame is pushed out of the ignitor/ burner mouth : Fuel or/ and air flow insufficient.
- .4.1 Remedy: Check complete wiring with test diode A10Z2. See manual.

14.4 Shut off during operation

Possible Causes:

- .1 Varying back pressures or supply pressures cause the flame to trip.
- 
- .2 Pilot flame is strongly influenced or when suffocated by the main flame.

Possible Reasons / remedy

- .1.1 Check pressure at the test nipples. Fluctuations require a differential pressure regulator on the air and fuel supply side.
- .1.2 Burner or ignitor test should be carried out outside combustion chamber.
Local safety regulations must be observed.
- .2.1 Remedy: Change position
- .2.2 Remedy: A more powerful burner/ ignitor may be requested.

14.5 Automatic shut-down at start-up when a flame is reported before the ignition fuel valve have been opened

Possible Causes:

- .1 Flame has not extinguished after the previous shut-down due to a leaking valve and is still present when system is restarted.

Possible Reasons / remedy

- .1.1 Remedy : Replace valve.

14.6 Electrical Malfunction

- .1 Burner control does not start
 - .1.1 Remedy: Devices of a different make can cause trouble. See chapter.
- .2 Burner/ Ignitor burner control are in operation but the release contact does not work.
 - .2.1 Check built in fuse (2AT).

In case of questions please give us the exact type designation as given on the nameplate.

15. Approvals

CE 0085

EG-Baumusterprüfbescheinigung

gemäß der EG-Gasgeräte-richtlinie (90/396/EWG)

EC type-examination certificate

according to the EC Gas Appliances Directive (90/396/EEC)



Zertifizierungsstelle

Produkt-ID-Nummer

Product-ID-Number

CE-0085AU0259

Produkt-Identnummer
product identification number

Zertifikatinhaber <i>owner of certificate</i>	Hegwein GmbH & Co. KG Am Boschwerk 7, D-70469 Stuttgart
Vertreiber <i>distributor</i>	Hegwein GmbH & Co. KG Am Boschwerk 7, D-70469 Stuttgart
Produktart <i>product category</i>	Ausrüstungsteile für Gasgeräte: Feuerungsautomat für Gasgeräte/Gasbrenner
Produktbezeichnung <i>product description</i>	Gasfeuerungsautomat mit Ionisationsfühler
Modell / Typ <i>model</i>	Z 725 K ...
Prüfgrundlagen <i>basis of type examination</i>	DIN EN 298 02.1994)
Geräte-kategorien Versorgungsdrücke Bestimmungsländer <i>appliance categories</i> <i>supply pressures</i> <i>countries of destination</i>	AT, BE, CH, DE, DK, ES, FI, FR, GB, GR, IE, IS, IT, LU, NL, NO, PT, SE
Prüfbericht <i>test report</i>	GE 2743 vom 07.06.1999 (TÜV Bau- und Betriebstechnik, München)
Aktenzeichen <i>file number</i>	98-0663-GEE

21.07.1999 Rie-Fk

Datum, Bearbeiter, Leiter der Zertifizierungsstelle
date, issued by, head of certification body

DVGW-Zertifizierungsstelle - von der Deutschen Bundesregierung benannte und von der Europäischen Kommission offiziell registrierte Stelle für die Konformitätsbewertung von Gasgeräten

DVGW Certification Body - notified by the government of the Federal Republic of Germany and officially registered by the European Commission for conformity assessment of gas appliances



DVGW Deutscher Verein des Gas- und Wasserfaches e.V.

Technisch-wissenschaftliche Vereinigung

Zertifizierungsstelle

Josef-Wirmer-Straße 1-3
D-53123 Bonn

Telefon +49 (228) 91 88 807

Telefax +49 (228) 91 88 993

Produkt-ID-Nummer : CE-0085AU0259*Product-ID-Number***Elektrische Daten :** 110-115/120-125/220-230/240-250 V AC; 50/60 Hz; Schutzart: IP 00
electrical data

Typ <i>type</i>	Technische Daten <i>technical data</i>	Bemerkungen <i>remarks</i>
Z 725 K ...	Sicherheitszeit : 3/1 s	

Ausführungsvariante <i>type variation</i>	Erläuterung <i>explanation</i>
...2	zugelassen für: intermittierenden Betrieb; geeignet für: Gaszündbrenner Typ ZR... sowie Gasbrenner Typ BR... der Fa. Hegwein Identifikationscode: A/M/L/L/X/N
...3	zugelassen für: intermittierenden und Dauerbetrieb; geeignet für: Gaszündbrenner Typ ZD... sowie Gasbrenner Typ BD... der Fa. Hegwein Identifikationscode: A/M/L/L/X/K
...2/3	220-230 V AC
.../00M	110-115 V AC
.../00B	240-250 V AC
.../00C	120-125 V AC

Bemerkungen*remarks*

Max. zul. Feuerungswärmeleistung: beliebig (Startbelastung max. 120 kW oder maximal 33% der Nennwärmeleistung)

Die EG-Konformitätserklärung für das Bestimmungsland Schweiz darf erst dann ausgestellt werden, wenn die Schweiz die EG-Gasgeräte Richtlinie (90/396/EWG) in nationales Recht umgesetzt hat.



EG-Konformitätserklärung / *EC Declaration of Conformity*

Hersteller/ *Manufacturer* Georg Hegwein GmbH & Co. KG
 Anschrift/ *Address* Am Boschwerk 7, D-70469 Stuttgart
 Produktbezeichnung / *Product description* Gaszündbrenner Baureihe BR..., BD...
Gas fired ignitors BR..., BD...

Das bezeichnete Produkt stimmt mit den Vorschriften folgender europäischer Richtlinien überein, vorausgesetzt, dass es installiert, gewartet und entsprechend seiner Bestimmung eingesetzt wird. Die einschlägigen Vorschriften und Hinweise aus der Bedienungsanleitung sind zu beachten.

The described product complies with the following provisions of Council Directive, provided that it is installed, maintained and used in applications for which it was made, in accordance with relevant installation standards and manufacturer's instructions.

Richtlinie des Rates 90/396/EWG (Gasgeräte-Richtlinie)
Council Directive 90/396/EEC (Gas appliance directive)

Richtlinie des Rates 89/336/EWG (EMV-Richtlinie)
Council Directive 89/336/EEC (EMC Directive)

Richtlinie des Rates 73/23/EWG (Niederspannungsrichtlinie)
Council Directive 73/23/EEC (Low Voltage Directive)

Wir bestätigen die Konformität des oben bezeichneten Produkts mit folgenden Normen:

We confirm the conformity of the above mentioned product with the following standards:

EN 298
 EN 50081-1
 EN 50082-2
 EN 55011
 EN 60730-1

Aussteller / *Issuer* Georg Hegwein GmbH & Co. KG

Ort, Datum / *Place, date* Stuttgart, 20.09.2003

Rechtsverbindliche Unterschrift / *Legally binding signature*

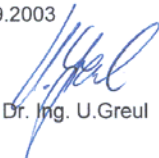
 Dr. Ing. U. Greul

\\PRIMERGY060\Vertrieb\Vorlagen\Formulare\Konformität\KONF_BD.doc

16.12.2003 15:03

Georg Hegwein GmbH + Co. KG
 Am Boschwerk 7
 D-70469 Stuttgart
 Tel.: +49 711 13 57 88-0
 Fax: +49 711 13 57 88-5

Banken: Deutsche Bank Stuttgart 9 212 200
 BLZ 600 700 70
 IBAN: DE04600700700921220000
 SWIFT: DEUTDE33
 Postbank Stuttgart 655 36-705
 BLZ 600 100 70

Kommanditgesellschaft:
 Stuttgart HRA 4951
 USt-IdNr.:
 DE 147 512 966
 Steuernummer/Tax ID:
 93153/01730

Persönlich haftende Gesellschafterin:
 Hegwein GmbH
 Stuttgart HRB 4303
 Geschäftsführung:
 Prof. Dr.-Ing. Peter Martin (Vorsitzender),
 Dr.-Ing. Ulrich Greul

DURAG GROUP
*Solutions for Emission
 and Combustion*
 www.hegwein.de
 e-mail: hegwein@durag.de