

Hegweïn

STUTT GART

Flame Relay A 285 K 2.3

for rail mounting to EN 60715



Designed to work

with Hegweïn Burners of the BA... Series
or
with Hegweïn Ignitors of the ZA... Series

1. Technical Data

Coil voltage	90 - 110 VDC +10%/ -15%
Max. contact load	max. 1 A (ohmic) at 250 VAC
Mechanical lifetime	$\geq 1 \times 10^6$ switching numbers
Electr. lifetime	250,000 switching numbers 250 VAC/ 1A/ ohmic
Screw-type terminals	
for wire size.....	0.5 - 2.5 mm ² solid or stranded wire with sleeve
Max. cable length	
Ignitor – flame relay	150 m
Mounting	on 35 mm rails according to EN 60715
Protection enclosure.....	IP 40
Protection terminal strip.....	IP 20
Enclosure material.....	Polycarbonat/ terminal strip Polyamid
Mounting position.....	any
Ambient temperature.....	- 20 up to + 60 °C
	Do not drop the dew point
Weight	0.17 kg

2. Operation, Storage, Dimensions and Lifetime

The flame relay is activated by the flame signal voltage from the flame monitor of the burner or ignitor which causes the 2 contacts to change over. A yellow LED behind the transparent front panel indicates a burning ignitor flame.

One contact has to be safely integrated into the main burner management control scheme so as to fully comply either with the requirements of EN 298 or with the codes of practice and/or standards, which apply in the country of installation. The fuel valve must not be opened if the relay has not been in its rest position.

Furthermore it should be ensured that the ignition voltage (terminals 8 or wire 4 of the burner or ignitor) is switched off before the ignition safety time elapses, i.e. a short sparkless period is available which will allow the safe rushing in of the flame relay. A spark firing throughout the entire safety time could suppress the flame signal completely.

This monitoring system is switched on and off by energizing the burner's or ignitor's input terminals/ wires 1 and 2.

Device are to be stored in a dry and dust-free place. Ambient temperature during storage shall be 0 – 60 °C. No operation and storage below dew point. Moisture must not exceed 60 %. Device shall be protected from mechanical damages.

Safety related equipment! In case of a break down the unit has to be returned to the manufacturer for inspection.

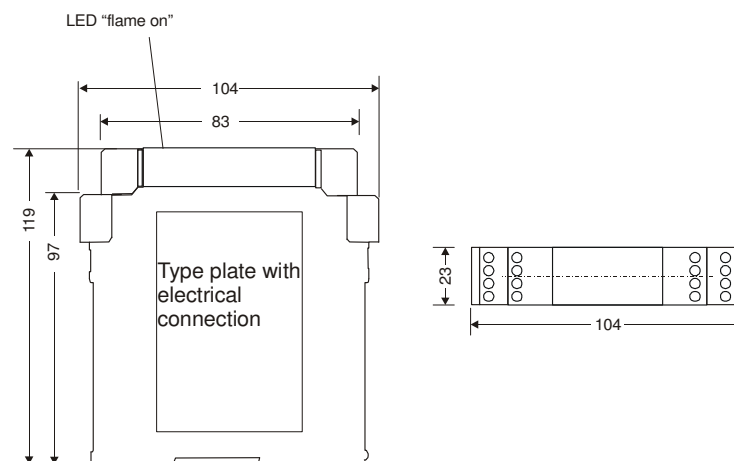

Dimensions

The device has a limited service life. It is designed for approx. 250,000 start ups. For 50 start ups per day its lifetime would be about 10 years. This time decreases under bad conditions e.g. dust, high or low temperature, moisture, vibrations, aggressive gases. The end user shall therefore take care that regular safety related maintenance checks are carried out at site.

When the appliance has reached the end of its lifetime it must be disposed of according to local regulations.

3. Electrical Connection

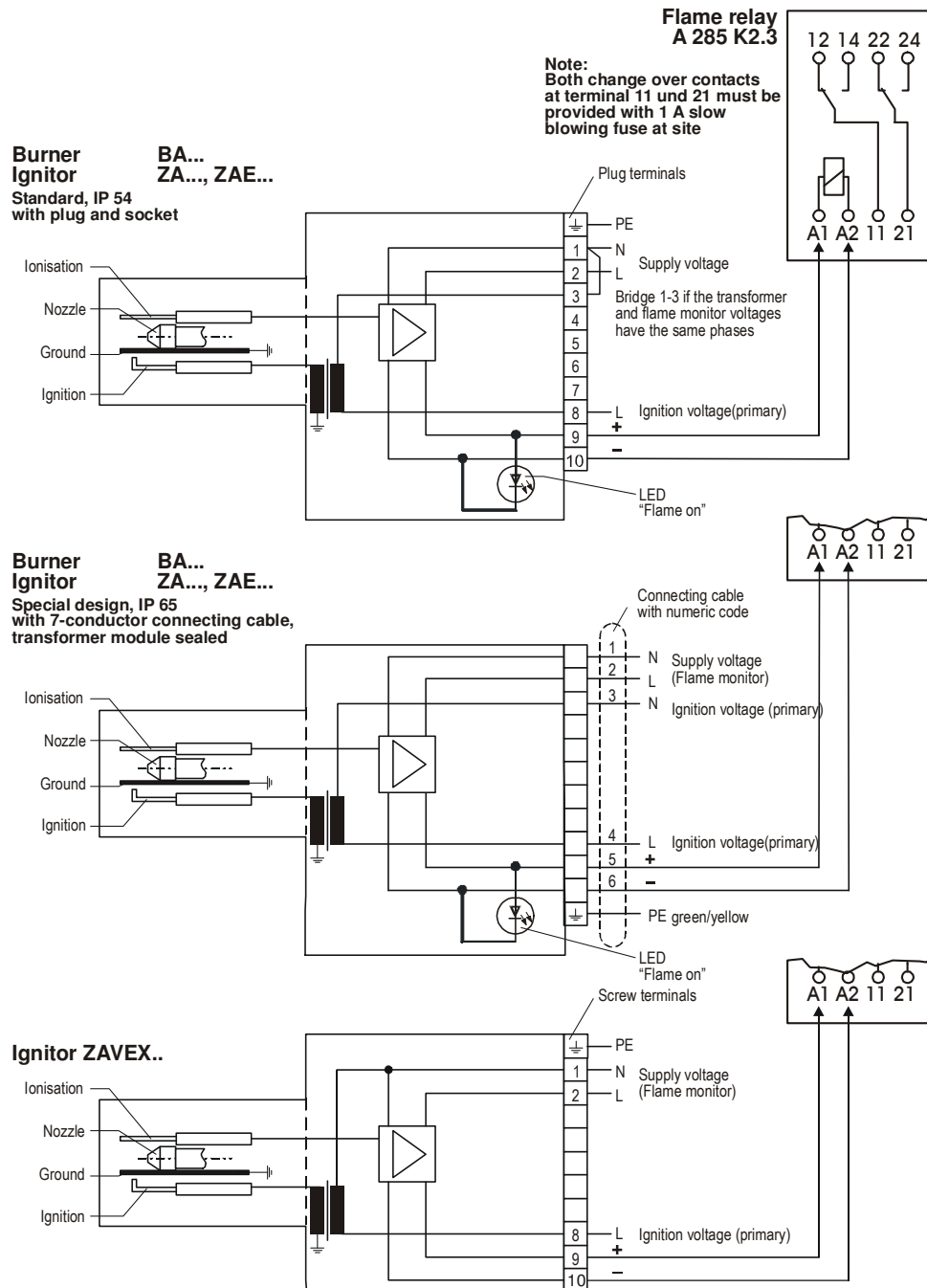

Warning instructions

- **Installation and maintenance procedures may only be carried out by authorized personnel**
- **All local regulations must be observed during installation**
- **Improper installation, alignment and maintenance, as well as modifications by the customer, can all lead to personal injury or property damage, as well as loss of warranty**