



OEM AIR PRESSURE SENSING SWITCHES WITH FIXED SET POINTS

APPLICATION

Series ANA Switches are specifically designed for OEM markets where customer-specified fixed set points between 0.05" and 12.0" w.c. are required. **ANA Switches** are used to sense positive, negative, or differential air pressure. They are supplied with various sample line connections, terminal styles, and mounting arrangements.

GENERAL DESCRIPTION & OPERATION

The plated housing contains a diaphragm and a SPDT or SPST snap-acting switch. The switch operates on pressure rise or fall at desired set point. For additional application and technical information, please contact the sales office.

MOUNTING (SEE FIGURE 1)

Select a mounting location which is free from vibration. The ANA switch must be mounted with the diaphragm in any vertical plane in order to maintain the specified operating set point. Avoid mounting with the sample line connections in the "up" position.

AIR SAMPLING

CONNECTION (SEE FIG. 2)

The ANA can be supplied with one or two sample line connections, situated on either side of the diaphragm as shown in

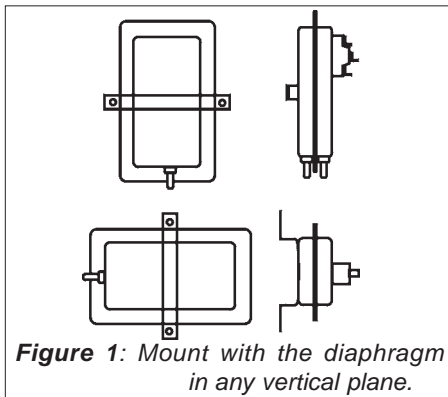
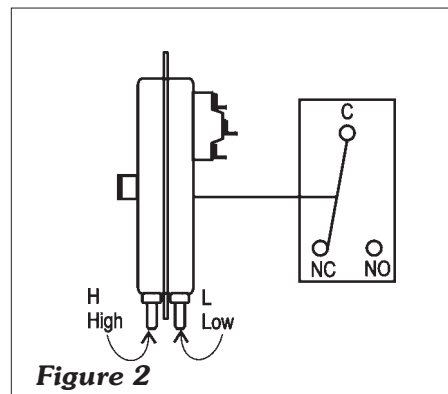

Figure 2. These connections are suitable for flexible or metallic tubing. Locate the sampling probe a minimum of 1.5 duct diameters downstream from the air source. Install the sampling probe as close to the center of the airstream as possible. Refer to **Figure 2** to identify the **high pressure inlet (H)** and the **low pressure inlet (L)**. Select one of the five application options listed below, and connect the sample lines as recommended.

Positive pressure only: Connect the sample line to inlet **H**; inlet **L** remains open to the atmosphere.

Negative pressure only: Connect the sample line to inlet **L**; inlet **H** remains open to the atmosphere.



Two Negative Samples: Connect the higher negative sample to inlet **L**. Connect the lower negative sample to inlet **H**.

Two Positive Samples: Connect the higher positive sample to inlet **H**. Connect the lower positive sample to inlet **L**.

One Positive & One Negative Sample: Connect the positive sample to inlet **H**. Connect the negative sample to inlet **L**.

ELECTRICAL

CONNECTIONS (FIGS. 2 & 3)

Before pressure is applied to the diaphragm, the switch contacts will be in the normally closed (NC) position. Control and alarm functions are wired as shown in **Figure 3**.

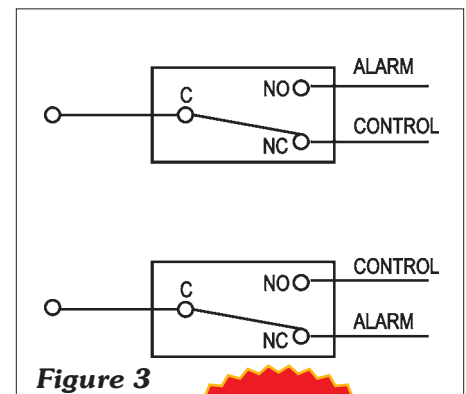

SPECIFICATIONS

SERIES ANA AIR PRESSURE SENSING SWITCHES

Range:

0.05 ± 0.02" w.c. to 12.0" w.c.

Switch Differential:

Progressive, from 0.02" ± 0.01" w.c. at minimum set point, to approximately 0.8" w.c. at maximum set point.

Maximum Pressure:

½ psi (0.03 bar).

Electrical Rating:

300 VA pilot duty at 115 to 277 VAC; 15 amp noninductive; to 277 VAC, 60 Hz.

Electrical Switch:

Snap-action switch.

Contact Arrangement:

SPDT, SPST/NO or SPST/NC logic.

Electrical Connections: Complying with the latest NEMA standards.

Operating Temperature Range:

-40 to 180F (-40.0 to 82.2C).

Mounting Position:

Diaphragm in any vertical plane to obtain specified operating set point.

Sample Line Connectors: Per customer requirement, for flexible or metallic tubing.

Shipping Weight: 1.2 lbs.

Approvals: UL, CSA, CE.

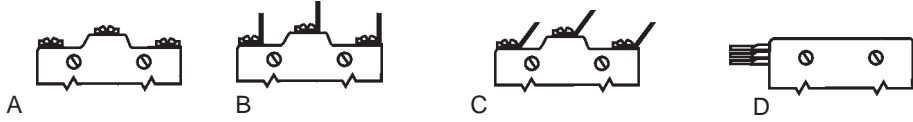

Figure 4. Typical Terminal Styles for Series ANA Switches:

A. Screw terminals with cup washers.

B. 1/4" - 90° "quick-connect" spade terminals.

C. 1/4" - 45° "quick-connect" spade terminals.

D. Three 18-gauge wire leads in temflex.

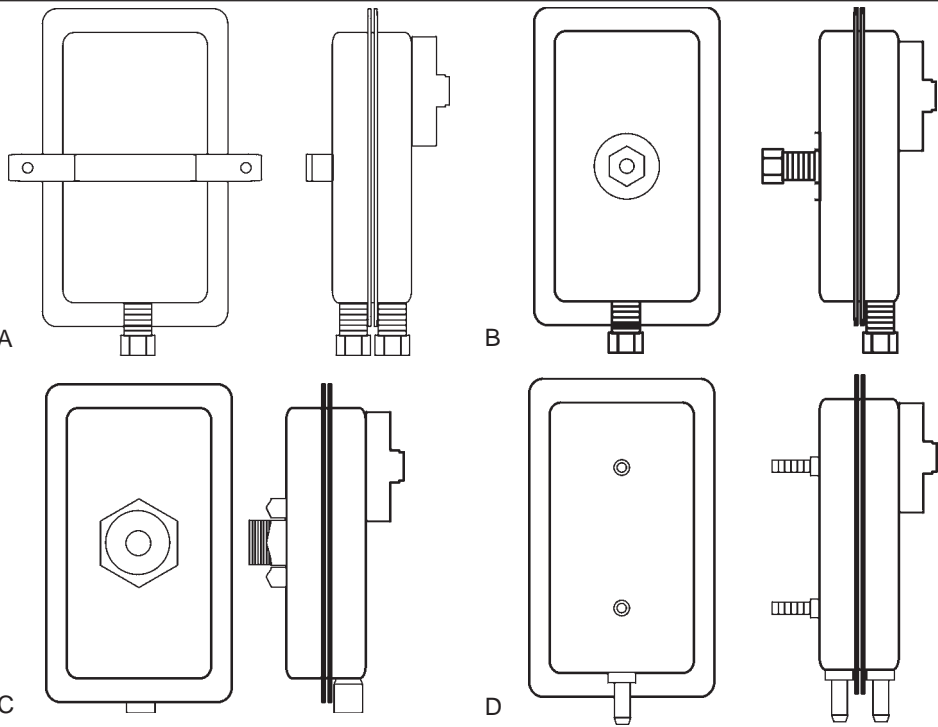

Fig. 5. Typical Mounting Styles for Series ANA Switches:

A. Foot bracket.

B. 7/16" - 24 UNS thread with nut.

C. 1" - 14 UNS "PAL" nut.

D. #10 -32 UNF studs.

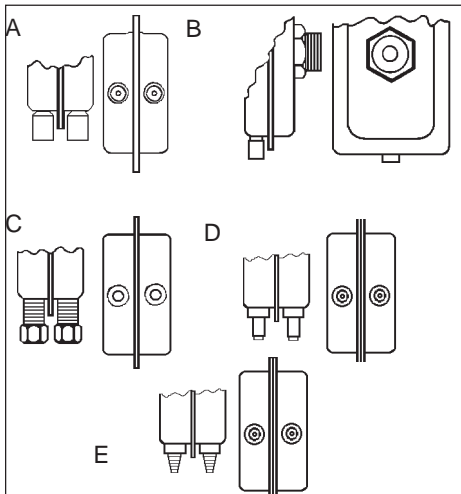

Figure 6. Typical Sample Line Connection Configurations for Series ANA Switches:

A. 1/8" - 27 NPT female thread.

B. 1/4" - 18 NPT female thread combined with 1/8" - 27 NPT female thread.

C. 1/4" compression nut and ferrule.

D. 1/4" OD slip-on fitting.

E. 1/4" OD barbed connections suitable for flexible plastic tubing.

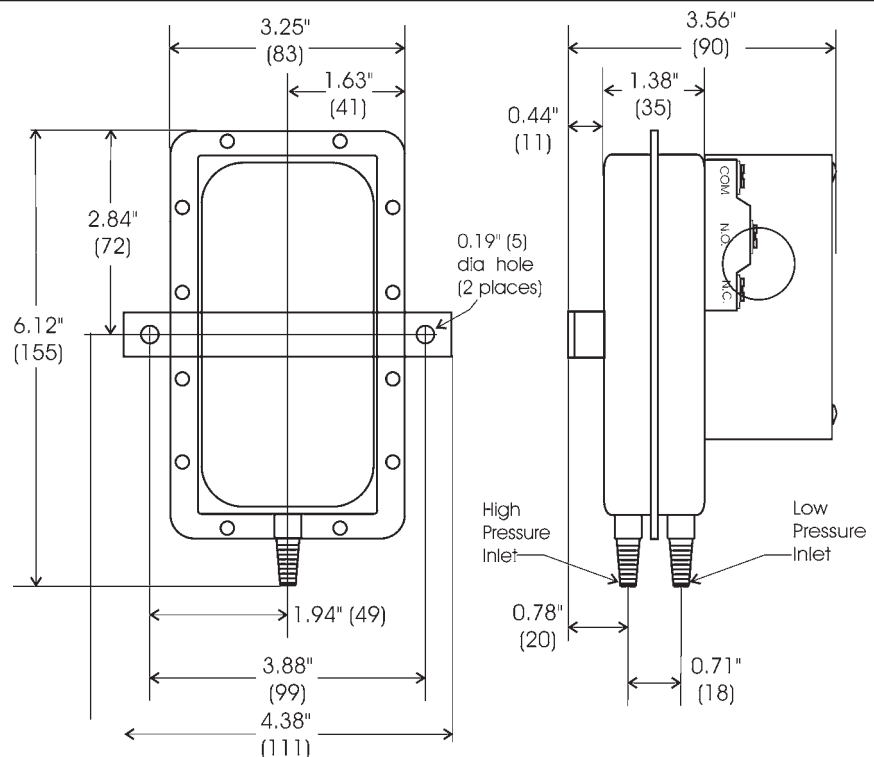

Figure 7 (Dimensions): Typical ANA Configuration, with strap mounting bracket, barbed air sample line connectors, screw terminals and enclosure cover.