

# Operating and mounting manual

## Safety shut off valve gas – solenoid valve

### EVA

## Contents

- 1.0 General remarks**
  - 1.1 Valve data
  - 1.2 Application
- 2.0 Danger Notices**
  - 2.1 Safety terms
  - 2.2 Safety notice
  - 2.3 Qualified staff
  - 2.4 Unauthorized modification and spare part production
  - 2.5 Unauthorized operation
  - 2.6 Safety information for the use in explosion-prone areas guideline 94/9/EC
- 3.0 Handling**
  - 3.1 Transport
  - 3.2 Storage
  - 3.3 Handling before mounting
- 4.0 Product Description**
  - 4.1 Function
  - 4.2 Technical Data
  - 4.3 Marking
- 5.0 Installation**
  - 5.1 Warning of Dangers during Installation, Operation and Maintenance
  - 5.2 Installation
- 6.0 Operation**
  - 6.1 Commissioning
  - 6.2 Shutting down
  - 6.3 Maintenance
  - 6.4 Putting back into Operating
- 7.0 Troubleshooting**
  - 7.1 Detection of defects
  - 7.2 Troubleshooting Plan
- 8.0 Dismantling of the Valve**
  - 8.1 Replacement of Wear Parts
- 9.0 Warranty**
- 10.0 Explanations on Codes and Directives**
- 11.0 Sectional Drawing**
  - 11.1 Sectional drawing
  - 11.2 List of parts
- 12.0 Declaration of Conformity**

## 1.0 General remarks

This operating manual includes instructions to assemble and operate the valve in the prescribed and safe way. **Additionally, the adequate operating instructions (BTA) of each special solenoid drive must be considered.**

Series MG...	220.100.038
Series MG...X	220.100.040
Series MG...Xme	220.100.039

If any difficulties appear that can not be solved by means of the operating manual, further information may be demanded from the manufacturer.

This operating manual is in accordance with the relevant valid EN safety standards and the valid prescriptions and rules of the Federal Republic of Germany.

If the solenoids are used abroad of the FRG, the operator and/or the person who is responsible for the plant concept must take care that the valid national rules are met.

The manufacturer reserves the right of any technical change and improvement.

The use of these operating instructions suppose the qualification of the user according to paragraph 2.3 "qualified staff".

The operating staff must be trained in accordance with the operating instructions. The operating manual must always be available at the location where used.

### 1.1 Valve Instruction

#### Manufacturer:

UNI Geräte E. Mangelmann  
Elektrotechnische Fabrik GmbH  
Holtumsweg 13  
D-47652 Weeze  
Telefon: +49 (0) 2837/9134-0  
Fax: +49 (0) 2837/1444  
E-Mail: [info@uni-geraete.de](mailto:info@uni-geraete.de)  
Homepage: [www.uni-geraete.de](http://www.uni-geraete.de)

#### Designation

Directly functioning, currentless closed, spring safety shut off valve with solenoid drive.

**Type test acc. :** to 90/396/EEC

**DIN EN 161** Kl. A, Gr. 2

**DIN 3394-1** Gr. 2

<b>Working pressure:</b>	02 - EVA	0 - 0,2 bar
	03 - EVA	0 - 0,3 bar
	05 - EVA	0 - 0,5 bar
	08 - EVA	0 - 0,8 bar
	1 - EVA	0 - 1 bar
	10 - EVA	0 - 10 bar
	20 - EVA	0 - 20 bar

**Fitting position:** vertical drive  $\pm 5^\circ$ , with order supplement „W“ horizontal.

<b>Working pressure:</b>	1 - EVA 36/56	0 - 1 bar
	5 - EVA	0 - 5 bar
	6 - EVA	0 - 6 bar
	25 - EVA	0 - 25 bar
	40 - EVA	0 - 40 bar

**Fitting position:** vertical or horizontal drive.

**Ambient temperature:** -20°C to + 60°C

**Medium temperature:** -20°C to + 60°C

**Switching cycles:** 1000 cycles/h for solenoid drives with one winding,  
20 cycles/h for solenoid drives with pickup and holding  
winding MG...A<sub>1</sub>/ A<sub>2</sub>/ A<sub>3</sub> see section 4.2.  
600 cycles/h for MG...A5

**Threaded connection dimension at DIN ISO 228-1**

Connection G	Prod. Id. CE-0085	1/4	3/8	1/2	3/4	1	1 1/4	1 1/2	2	Design pressure PS = PN
03-EVA	AQ0563	X	X	X	X	X	X	X	X	PN 6
08-EVA	AQ0563	-	-	-	-	-	-	-	X	PN 6
1 -EVA	AQ0563	X	X	X	X	X	X	X	-	PN 6
1 -EVA 36	AQ0563	-	X	-	-	-	-	-	-	PN 6
1 -EVA 56	AQ0563	-	-	X	-	-	-	-	-	PN 6
5 -EVA 24	AQ0563	X	-	-	-	-	-	-	-	PN 10
5 -EVA 5	AR 0219	-	-	X	-	-	-	-	-	PN 10
6 -EVA 24	AQ0563	X	-	-	-	-	-	-	-	PN 10
25- EVA 23	AT0196	X	-	-	-	-	-	-	-	PN 40
40- EVA 23	AQ0726	X	-	-	-	-	-	-	-	PN 40

X Type test acc. to 90/9396/EEC, O Acceptance test certificate 3.2 possible, - not available,

**Flange connection measures acc. to DIN EN 1092-2 / ANSI**

Flange DN ANSI	PN	Prod. Id. CE-0085	15	20	25	32	40	50	65	80	100	125	150	200	Design pressure PS = PN
			1/2"	3/4"	1"	1 1/4"	1 1/2"	2"	2 1/2"	3"	4"	-	6"	8"	
02- EVA	16	AQ0563	X	X	X	X	X	X	X	X	X	X	X	X	PN 6
05- EVA	16	AQ0563	X	X	X	X	X	X	X	X	X	X	X	X	PN 6
1 - EVA	16	AQ0563	-	-	-	-	-	X	X	X	X	X	-	-	PN 6
10 - EVA	16	AR0409	X	-	-	-	-	-	-	-	-	-	-	-	PN 25
20 - EVA	25	AR0409	X	-	-	-	-	-	-	-	-	-	-	-	PN 40

X Type test acc. to 90/9396/EEC, O Acceptance test certificate 3.2 possible, - not available,

**Voltage:** 24V– 420V (–15% bis +10%)  
**Protection type:** IP54 or IP65  
**Frequency** 40 – 60 Hz  
**Power** 10 – 4000W

Details to the electrical data can be found on the type sign and the adequate operating instructions of the solenoid valves.

**1.2 Application**

The UNI Geräte Gas – Solenoid valves EVA are used as automatic safety shut-off valves for protection, limitation, shut-off and release of gas and air supply at main stops of in front of gas burners. e.g. to DIN EN 161, DIN 3394-1.

The valves are suitable for gases of the 1<sup>st</sup>, 2<sup>nd</sup> and 3<sup>rd</sup> gas families to G260 and for neutral gases and as a variant with material design for aggressive gases such as e.g. biogas, sewage plant gas or dump gas to G262.

If used in other cases, the operator must carefully check if construction/design of valve, accessories and materials are suitable for the new application. The range of application is subject to the responsibility of the plant planner. The service life of the valve is 20 years.

**2.0 Danger Notices**

**2.1 Safety Terms**

The signal terms DANGER, CAUTION und NOTICE are used in this operating manual in case of notices concerning special dangers or for unusual information requiring a special marking.



**DANGER!** means that in case of non-observance there is danger to life and/or considerable damage.



**CAUTION!** means that in case of non-observance there is danger of injury and/or damage.



**NOTICE!** means that attention is drawn to technical correlations/connections.

Observance of other, not especially marked notices concerning transport, assembly, operation and maintenance and other data (in the operation instructions, product documentation and at the unit itself) is also essential, in order to avoid disturbances that might affect direct or indirect damage to property or injury to persons.

## 2.2 Safety Notice

Non observance of safety instructions can lead to loss of any claim for damages.

Non observance can lead to the following mentioned dangers:

- Failure of important functions of the valve/plant
- Endangering of persons by electrical or mechanical influences.
- Protection against accidental contact for moving parts may not be removed as long as the valve is in operation.
- Leakage of dangerous media (e.g. explosive, toxic, hot) must be removed in the way that there is no danger for persons or environment. Laws and regulations must be observed.

## 2.3 Qualified Personnel

These are persons who are familiar with erection, assembly, starting, operation and maintenance of the product and who have special qualifications acc. to their activities and functions, e.g.:

- Instruction and obligation to carry out and meet all regional and in-house orders and requirements.
- Education or instruction according to the safety engineering standards in use and maintenance of adequate safety and working protection equipment.
- Training in first aid.

## 2.4 Unauthorized Modification and Spare Part Production

Modification or changes of the valve are only allowed after agreement of the manufacturer. Original drawings and accessories authorized by the manufacturer are for safety purposes. The use of other parts or unauthorized constructive changes at the valve by third persons may cancel and abolish the manufacturer's liability for resulting consequences.

## 2.5 Unauthorized Operation

Operational reliability of the delivered valve is only guaranteed in case of determined use in accordance to paragraph 1 of the operating manual. **The application limits mentioned on the type sign may on no account be exceeded.**

## 2.6 Safety information for the use in explosion-prone areas guideline 94/9/EC

- The temperature of the medium must not exceed the respective temperature class, and respectively, the respective maximum permitted medium temperature as per operation guideline.
- If the valve is heated (e.g. heating jacket), care must be taken, that the specified temperature class is kept in the time.
- The valve must be connected to the ground.  
In the case most simple this can be realized via pipe screws by means of tooth disc.  
Otherwise the connection to the ground must be implemented by other measures e.g. cable links.
- Control valves, electrical and electrical/mechanical drives as well as sensors must undergo a separate conformity check as per ATEX. In doing so the respective safety and explosion protection information in the operation instructions are to taken into special consideration.

Furthermore we point out the guideline 95/C332/06(ATEX 118a), which include the minimum regulations for the improvement of the health-related situation and the safety of the employees, who might be jeopardized by an explosive atmosphere.

### 3.0 Handling

#### 3.1 Transport

For any transport works, the generally recognised technical rules and standards as well as rules for prevention of accidents must be observed.

In case of transport, storage and stopping, the flange protection caps must be mounted at both valve flanges.

The goods to be transported must be carefully treated. During transport, the valve must be protected against strokes, impacts or vibration. The coat of lacquer may not be damaged. Transport temperature is  $-20^{\circ}\text{C}$  up to  $+60^{\circ}\text{C}$ .

**Never transport the valve at screwed cable glands, appliance plugs or add-on units.** The valve can be transported at ring nuts, flange borings or by means of a belt under the solenoid drive.

Transport the valve in a case or on a pallet with smooth base and put it softly on plain floor. **Never put the valve on limit switch box.**

The goods must be checked on completeness and transport damage. See also section 9.0

#### 3.2 Storage

If the valve is not installed immediately after delivery, it must be stored properly.

- Storage temperature  $-20^{\circ}\text{C}$  up to  $+60^{\circ}\text{C}$ , dry and clean.
- The lacquer protects against corrosion in neutral dry atmosphere. Do not damage colour.
- In humid rooms, a drying agent or a heating resp. is necessary because of condensation of water.

Requirements according to DIN 7716 (products made of caoutchouc and rubber) must be met.

#### 3.3 Handling before Assembly

- In case of valve with protection caps, they must be removed before being mounted!
- Protect against atmospheric influences such as humidity (otherwise use drying agent).
- Appropriate treatment protects against damage.

### 4.0 Product description

The UNI-Geräte gas – solenoid valve EVA is a directly controlled, currentless closed, safety shut-off valve acc. to DIN EN 13611, DIN 3394-1 and DIN EN 161 with solenoid drive.

Sectional drawing 11.1 Fig. 1 - 7 shows the valve construction.

#### 4.1 Function

By switching on the solenoid drive, the solenoid core (207) is drawn against the upper part (104). The pressure spring (503) is pressed and the valve disc (200) releases the valve cross section. The valve is open.

The valve opened by switching off, interruption or failure of power energy to solenoid drive. Due to press of the pressure spring (503) the valve disc closes (200). The valve is opened at 15% of nominal voltage.

#### 4.2 Technical Data

**Opening times:** 0,3 – 0,7s  
**Closing times:** < 1s

**Solenoid –drive types MG...**

Connection G	1/4	3/8	1/2	3/4	1	1 1/4	1 1/2	2
<b>03-EVA</b>	3803 0801	004	004	005-3	005-3	008-2	010	012
<b>08-EVA</b>	-	-	-	-	-	-	-	016
<b>1 - EVA</b>	004	005-3	005-3	008-2	010	012	014	-
<b>1 - EVA 36</b>	-	004	-	-	-	-	-	-
<b>1 - EVA 56</b>	-	-	004	-	-	-	-	-
<b>5 - EVA 24</b>	004	-	-	-	-	-	-	-
<b>5 - EVA 5</b>	-	-	010	-	-	-	-	-
<b>6 - EVA 24</b>	004	-	-	-	-	-	-	-
<b>25 - EVA 23</b>	005-3	-	-	-	-	-	-	-
<b>40 - EVA 23</b>	005-3	-	-	-	-	-	-	-

**Solenoid –drive types MG...**

Flange DN Flange ANSI	15 1/2"	20 3/4"	25 1"	32 1 1/4"	40 1 1/2"	50 2"	65 2 1/2"	80 3"	100 4"	125 -	150 6"	200 8"
<b>02-EVA</b>	008-2	008-2	008-2	008-2	012	014	016	018	019A5	018A1	019A2	020A2
<b>05-EVA</b>	008-2	008-2	010	010	014	016	018	019A5	018A2	019A2	020A1	020A2
<b>1 - EVA</b>	-	-	-	-	-	016A1	018A1	018A1	019A2	019A3	-	-
<b>10 - EVA</b>	014	-	-	-	-	-	-	-	-	-	-	-
<b>20 - EVA</b>	016	-	-	-	-	-	-	-	-	-	-	-

Drive types with "A" consist of pickup and holding winding

**Max. valve loading by pipe power**

The indicated moments may not work longer than 10s.

DN	8	10	15	20	25	32	40	50	65	80	100	125	≥150
<b>Torsion Nm</b>	80	35	50	86	125	160	200	250 <sup>1)</sup>	325 <sup>1)</sup>	400 <sup>1)</sup>	-	-	-
<b>Bending Nm</b>	35	70	105	225	340	475	610	1100	1600	2400	5000	6000	7600

<sup>1)</sup> Not valid in case of valves with flanges

**Starting torque, pipe screws greased**

DN	8	10	15	20	25	32	40	50	65	80	100	125	≥150
<b>Torque Nm</b>	20	30	30	30	30	50	50	50	50	50	80	160	160

**Starting torque, product screws and nuts greased**

Screw	M6	M8	M10	M12	M16	M20	M24
<b>Torque Nm</b>	5	11	22	39	70	110	150

**4.3 Marking**

The type sign on the solenoid drive has the following information:

- Fabricator
- Valve type, nominal width, pressure and temperature indication, fitting position
- Year of construction/ production no.
- Product ID No. to 90/396/EEC
- Valve class and valve group acc. to DIN EN 161, DIN 3394-1
- CE-sign and no. of relevant location to 97/23/EC
- Fluid group and test pressure PT to 97/23/EC
- Solenoid drive type
- Electr. performance
- Voltage
- Frequency
- Protection type

When using solenoid drives for x-protection zone 1 refer to information in the valid operating instructions.

Refer also to section 10.0.

## 5.0 Installation

### 5.1 Warning of Dangers during Installation, Operation and Maintenance



#### **DANGER!**

Safe operation of the valve can only be guaranteed if it is installed, commissioned and maintained by qualified personnel (see point 2.3 “Qualified staff”) correctly and in observance of the warnings in this operating manual. Apart from that, the operation safety order and the qualified use of tools and protection equipment must be guaranteed. The operating instructions for the valve must be observed during all work on or with the valve. Failure to observe these instructions may result in injury or in damage to the valve or other installations.

When the valve is used as a final sealing element, a safety precaution e.g. blanking disc, blind flange, etc., in accordance with the code of practice of the German Technical and Scientific Association for Gas and Water (DVGW) is recommended during all repair work.

### 5.2 Installation

Apart from the general installation guidelines, the following points should be observed:



#### **NOTICE!**

- Remove the flange covers.
- The inside of the valve and the pipeline must be free from foreign particles.
- Observe the installation position in relation to the flow direction, see markings on the valve.
- Centre gaskets between the flanges.
- The connecting flanges must be aligned.
- Ensure that none of the components is strained during installation.
- The valve must not be used as a fixed point; it is supported by the pipework system.
- Protect valves from soiling, particularly during construction work.
- Thermal expansion of the pipework must be equalized using compensators.

In accordance with DIN 3394-1 and DIN EN 161, a dirt trap must be installed upline of any safety shut-off device. The mesh size of the screen must be smaller than 1.5 mm and not allow a test mandrel of 1 mm diameter to pass. Where two safety shut-off devices are combined to form a group, one dirt trap installed upstream of the first valve is sufficient. The dirt trap must be installed not too far upline of the first valve. The UNI-Geräte dirt traps of the SF / SFR Series are approved for use together with the gas pneumatic valves in accordance with 90/396/EEC.

The valve can be installed with upright but not suspended solenoid drive. Valves with order suffix “W” in the type designation can be installed with horizontal solenoid drive.



#### **NOTICE!**

Please observe the solenoid drive operating instructions (BTA).

## 6.0 Operation



#### **DANGER!**

Before commissioning a new installation or before starting up an installation again after repairs or modifications, ensure:

- The proper completion of all installation and assembly work!
- Commissioning only by “qualified staff” (see point 2.3).
- Installation or repair of existing guards and protection equipment.

### 6.1 Commissioning

- Before commissioning, check the data on material, pressure, temperature and flow direction with the layout plan of the pipework system.
- Depending on the field of application, the local regulations have to be observed, e.g. the operation safety order.
- Residues in the pipework and the valve (dirt, weld beads, etc.) will inevitably result in leaks.
- Leakage inspection of the installed valve.

### 6.2 Shutting Down

- Depending on the field of application, the local regulations have to be observed, e.g. the operation safety order.

### 6.3 Maintenance

Solenoid valves have to be checked at regular intervals for proper function and internal leak tightness. The intervals for regular inspections have to be defined by the operator according to the operating conditions. UNI-Geräte recommends an internal visual inspection once a year and an overhaul of the valve after 2 years or after the following number of switching cycles at the latest:

Application temperature	DN ≤ 25	≤ DN 80	≤ DN 150	> DN 150
≤ 25°C	150 000	75 000	25 000	20 000
> 25°C	50 000	25 000	25 000	5 000

### 6.4 Putting Back into Operation

When putting a valve back into operation, ensure that all the necessary steps described in section 5.2 (Installation) and section 6.1 (Commissioning) are repeated.

## 7.0 Troubleshooting

### 7.1 Detection of defects



**DANGER!**

**Be sure to observe the safety instructions during troubleshooting.**

If the malfunctions cannot be remedied using the following **“Troubleshooting plan (7.2)”** please contact the manufacturer.

In the event of faults in the function or operating behaviour of the valve, check whether the installation work was carried out and completed as described in this operating manual. Depending on the field of application, the operation safety order must be observed.

Check the data on material, pressure, temperature, voltage and flow direction with the layout plan of the pipework system. In addition, check whether the operating conditions correspond to the technical data in the data sheet or on the rating plate.

### 7.2 Troubleshooting Plan

Malfunction	Possible causes	Remedy
No flow	Valve does not open	Switch on solenoid drive (800) Check operating voltage
	Working pressure too high	Compare working pressure with the data on the rating plate
	Flange covers were not removed	Remove flange covers
Low flow rate	Contaminated strainer	Filter clean/exchange
	Clogging in the pipework system	Check pipework system
Valve leaking at seat, no internal tightness	Valve seat gasket (400) or valve seat (100) damaged by external particles	See section 8 or replace valve

Malfunction	Possible causes	Remedy
No external tightness	Gaskets damaged	See section 8 or replace valve
Valve does not close	Connected voltage too high	Check whether there is residual voltage, see section 4.1
Flange fracture (valve/ pipework)	Screws not tightened uniformly, mating flanges not aligned	Align pipework. Install new valve



**NOTICE!**

Observe section 10.0 before all installation and repair work!

Observe section 6.4 when putting the valve back into operation!

## 8.0 Dismantling of the Valve

In addition to the general installation guidelines and the operation safety order, the following points must also be observed:



**DANGER!**

- Depressurised pipework system
- Cooled medium
- Emptied installation
- Vent pipework systems containing corrosive, inflammable, aggressive or toxic media
- Have dismantling work carried out only by qualified staff (see point 2.3)

### 8.1 Replacement of Wear Parts

Shut down the valve as described in section 6.2.

Switch off and dismantle the solenoid drive as described in the operating manual of the solenoid drive.



**DANGER!**

**After continuous operation, the solenoid drive may be hot! Danger of burns!**

During the visual inspection, pay attention to the following points:

1. Damage to the valve seat (100).
2. Damage to the valve disc sealing (400)
3. Wear of the guide rings (206)

In case of damage to the valve seat, replace the whole magnetic valve.

If the sealing element becomes damaged (only applies to flange version Fig.1 – 2; thread version Fig. 5), the spare parts kit should be used.

### Flange version

#### Fig.1 02 – 1-EVA

Loosen hex. head screw (900) and de-install the housing flange (108). Completely remove upper part of housing (106). Completely take interior part (200;201;203,207;214;503;950) out of valve housing (100) putting it onto a clean pad. Subsequently remove bolt (936) together with SL-retention (949) and de-install magnet core (207).

**Fig.2 10/20-EVA**

Loosen and remove setscrew (941). Unscrew upper part of housing (106) completely from separator. Subsequently remove bolt (936/2) together with SL-retention (949/2) and de-install magnet core (207) with spring bolt (210) and pressure spring (503). Loosen and remove hex. head screws (900) with north lock disc (948). Remove separator (110) with spindle guide (212) from valve housing (100). Completely remove valve disc (200;201;205;213;400;936/1;949/1;950) from valve housing putting it onto a clean pad. Subsequently remove bolt (936/1) together with SL-retention (949/1) and de-install the valve disc (200).

**Thread version**

**Fig.3 03-EVA 2**

**Fig.4 03-EVA 3-12; 1-EVA 2-7**

Replace the complete solenoid valve

**Fig.5 03-EVA 12-20; 08-EVA 20; 1-EVA 10-15**

Unscrew and remove upper part of housing (106) with O-Ring (403/2) from valve housing (100). Completely remove interior part (200, 201,203, 207,209, 214, 503) from the valve housing (100) putting it onto a clean pad. Subsequently remove bolt (936) together with SL-retention (949) and completely de-install the valve disc (200, 201,202, 400, 901/1, 903).

**Fig.6 5/6-EVA 24; 25-EVA 23; 40-EVA 23**

**Fig.7 5-EVA 5**

Replace the complete solenoid valve



**NOTICE!**

Before assembly, replace O-rings (403/X) and flat gasket (402).

Assemble the valve in the reverse order to the dismantling.



**CAUTION!**

Install wear parts carefully and properly and do not damage them during assembly.

Examine the valve for internal and external leaks in accordance with DIN 3394-1 and finally carry out a function test.

## 9.0 Warranty

Scope and period of the warranty is specified in the edition of the "General Terms of Business of the UNI-Geräte E. Mangelmann Elektrotechnische Fabrik GmbH" valid at the time of delivery or else in the purchase agreement.

We warranty that the valve is free from faults in line with the state of the art and for the confirmed field of application.

No warranty claims will be accepted for damage resulting from improper use or failure to observe these operating and installation instructions, the statutory accident prevention regulations, the EN, DIN and VDE standards and other codes and regulations.

Warranty claims will also not be accepted for damage occurring during operation due to operating conditions deviating from those specified in the data sheet or in other agreements.

Justified complaints will be remedied by reworking by us or specialist companies authorized by us.

Claims going beyond the scope of the warranty will not be accepted. The customer shall have no right to the supply of a replacement valve.

Maintenance work, installation of parts from other manufacturers, any modifications to the design and natural wear are not covered by the warranty.

Transport damage must be reported not to us but **without delay** to your responsible goods handling company, the railway company or the shipping agent as otherwise all claims for damages against these companies will be voided.

## 10.0 Explanations on Codes and Directives

The Commission of the European Union has laid down common directives for the free trading of goods within the Union specifying minimum requirements for safety and health protection. The CE symbol confirms that products comply with the EU directives, i.e. in conformity with the relevant, in particular harmonised standards. Directives 90/396/EEC, 2006/42/EC and 97/23/EC are of relevance for the gas solenoid valve (mechanical part).

### Notes on Directive 90/396/EEC (Appliances Burning Gaseous Fuels):

The valves have been developed, manufactured and tested in accordance with harmonised standard DIN EN 161 (DIN 3394-1, DIN 3391) and comply with the relevant requirements of the Union Directive 90/396/EEC. Unless otherwise stated separately, this has been confirmed by a type test.

### Notes on Directive 2006/42/EC (Machinery Directive):

The valves have been developed, manufactured and tested in accordance with Directive 2006/42/EC.

### Notes on Directive 97/23/EG (Pressure Equipment Directive, DGRL):

It has been confirmed that the quality assurance in design control, manufacture and final acceptance of the manufacturer, UNI-Geräte E. Mangelmann Elektrotechnische Fabrik GmbH, satisfy the requirements of 98/23/EC Annex III Module H. The gas solenoid valves comply with the fundamental requirements of Directive 97/23/EC. Valves with permissible working pressures  $\leq 0.5$  bar, DN  $\leq 25$  and all products certified in accordance with category I and with 94/396/EEC are not covered by 97/23/EC. Only products covered by DGRL and classified in category I or higher may be marked in accordance with 97/23/EC. Fluid group 1 includes explosive, inflammable and toxic media. Fluid group 2 includes media not belonging to fluid group 1.

Directives 2006/95/EC and 2004/108/EC are of relevance for the solenoid drive (800).

### Notes on Directive 2006/95/EC (Low Voltage Directive):

The drives have been developed, designed and manufactured in accordance with standard "Electromagnetic Devices" DIN EDV 0580. The requirements of the Low Voltage Directive that is applicable for rated voltages from 50 to 1000 V AC and 75 to 1500 V DC are therefore also satisfied.

### Note on Directive 2004/108/EC (EMC Directive):

The magnet fulfil the requirements of the product family standards EN 55014-1,-2, EN 61000-3-2, -3-3 for the industrial sector as well as for the sectors of housing, business and trade in small businesses.

When using AC and DC versions, the user must provide a suitable mains filter (e.g. X capacitor 47 nF) at the connection to the mains power supply in order to suppress the physical mains-borne turn-off interference of the solenoid coil.

Solenoid drives as drive elements for valves do not represent independently operated devices in the sense of the EMC Directive and are only further processed by specialist companies or are installed in a machine. Commissioning is not permitted until it has been determined that the whole machine or plant complies with the provisions of the EMC Directive.

For solenoid drives for explosion-proof zone 1, see the relevant operating manual for the solenoid drives.

### Note concerning ex-guideline 94/9/EC (explosion guideline ATEX):

The product is not subject to guideline 94/9/EC, since due to the loads occurring during practical operation, there is no effective source of ignition even in case of an error case to be assumed. This also applies for spring-loaded components, like for example the pneumatic drive. In case of electric drives, sensors or other electric components the application as per 94/9/EC is to be checked separately.

### National Codes and Directives

For the use of safety shut-off devices in accordance with DIN EN 12952-8 or DIN EN 746, the requirements of DIN EN 161 and DIN 3394-1 have to be satisfied. This is confirmed by a type test or by an acceptance test certificate to EN10204-3.2 (01/05).

Thread valves may be installed as follows:

DIN EN 746-2		DIN EN 12952-8	TRD 412		Comment
Pressure bar	Nom. dia.	Nom. dia.	Pressure bar	Nom. dia.	
≤ 0,1	≤ G 3	≤ G 2	≤ 4	≤ G 2	
≤ 2	≤ G 2		> 4	≤ G 1	Metal to metal joint
≤ 5	≤ G 1				

### 11.0 Sectional drawing

11.1 Fig.1 Flange design: 02 – 1-EVA

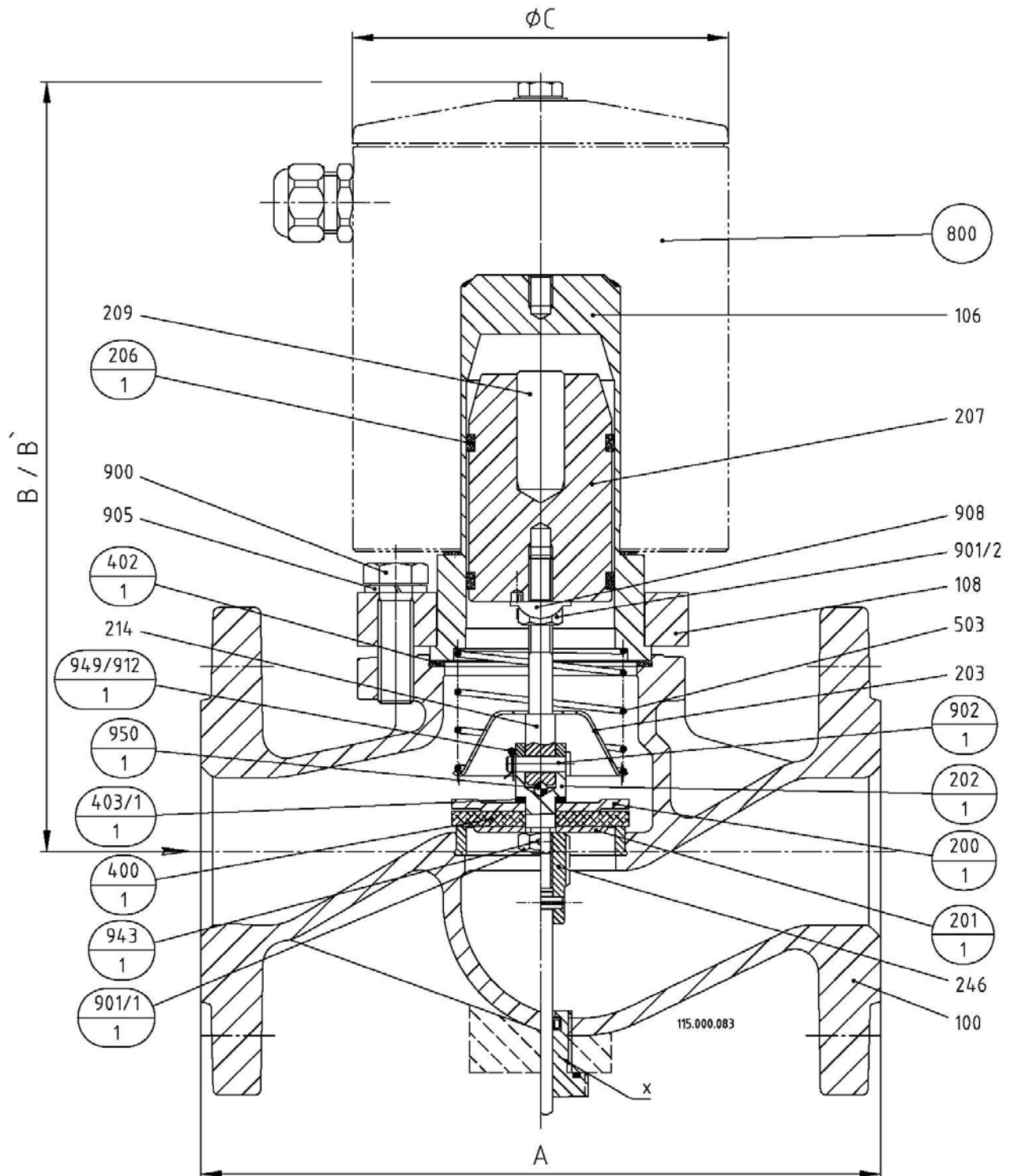

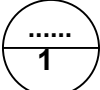
 = Spare part kit

**X** = Option limit switch mounting

Fig.2 Flange design: 10/20-EVA

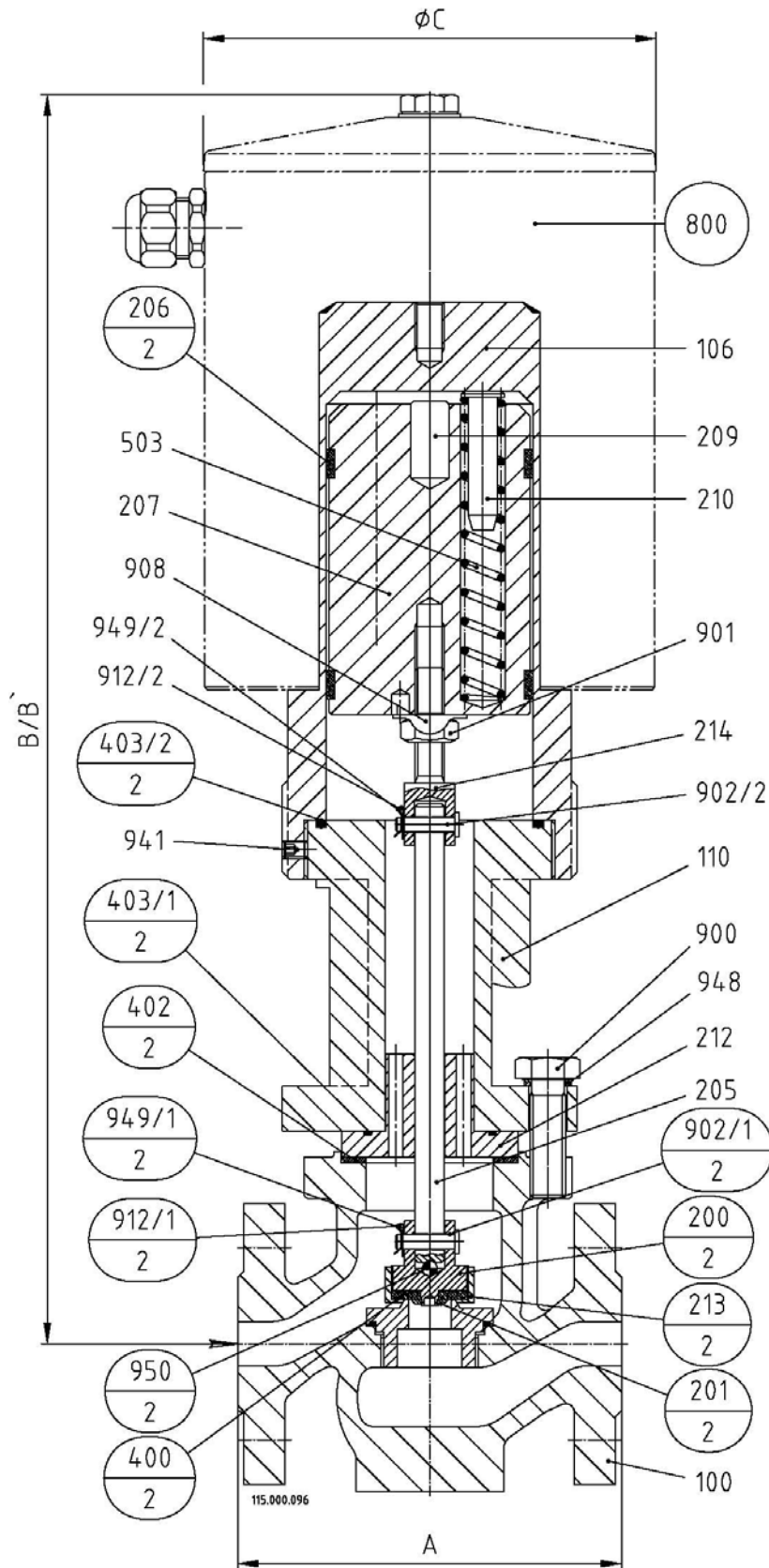

= Spare part kit

Fig.3 Thread design: 03-EVA 2

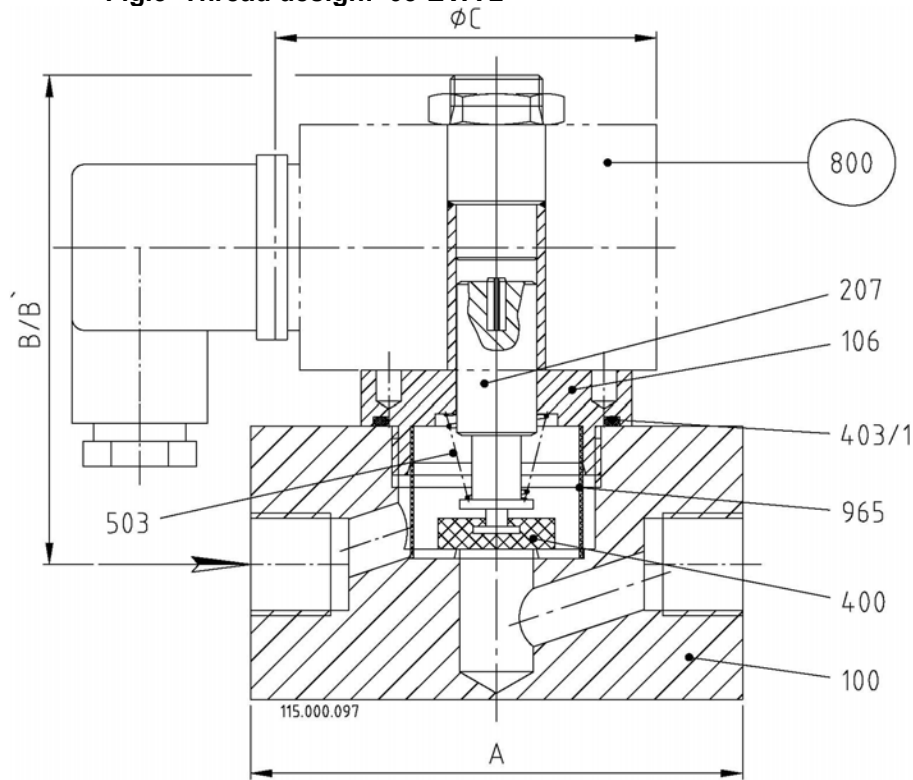

Fig.4 Thread design: 03-EVA 3-10; 1-EVA 2-7

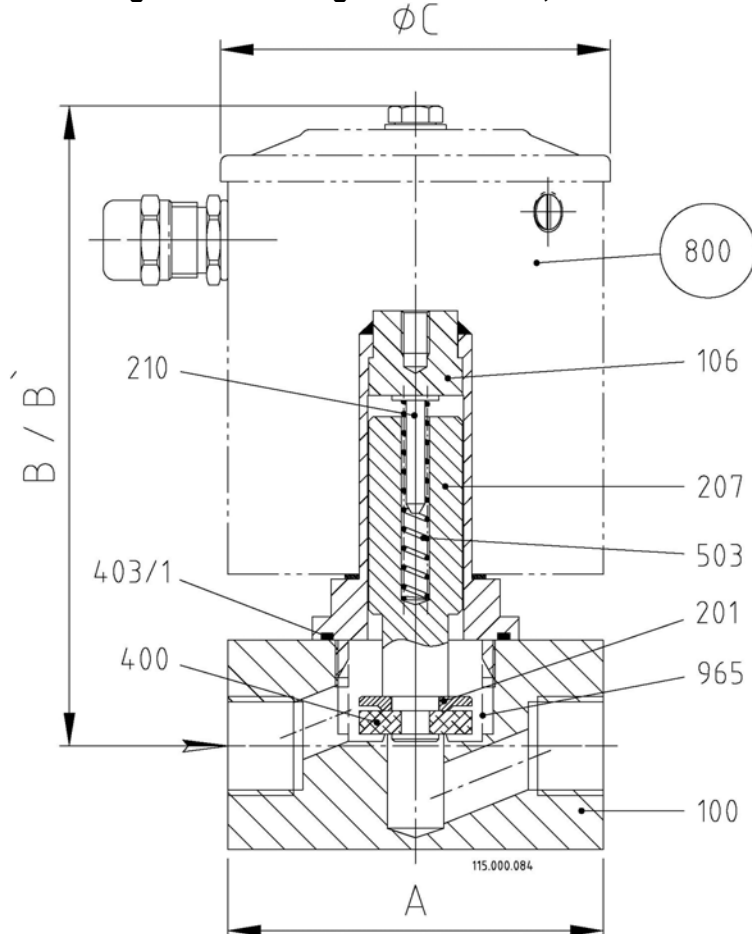
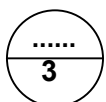
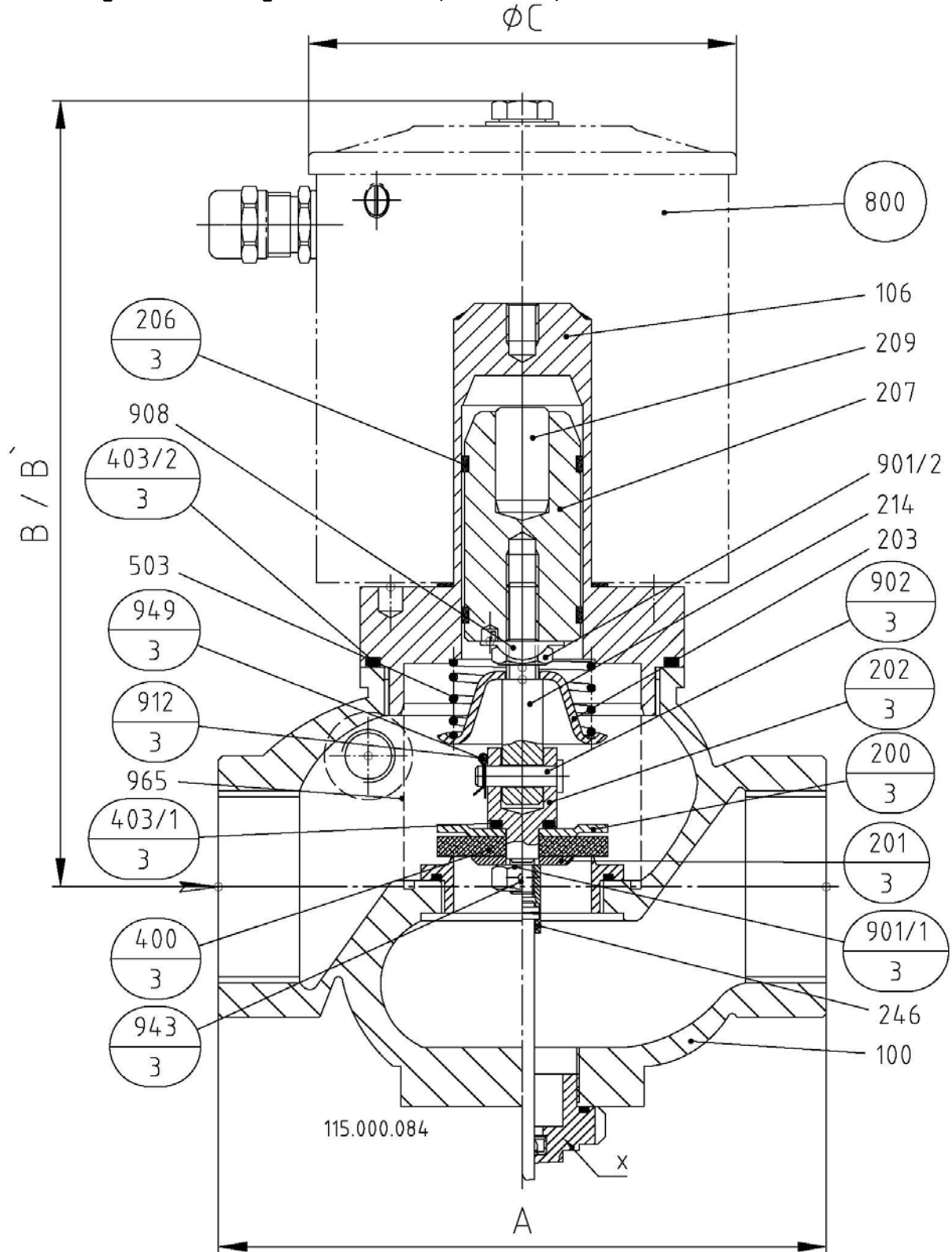

Fig.5 Thread design: 03-EVA 12-20; 08-EVA 20; 1-EVA 10-15



= Spare part kit

X = Option limit switch mounting

Fig.6 Thread design: 5/6-EVA 24; 25-EVA 23; 40-EVA 23

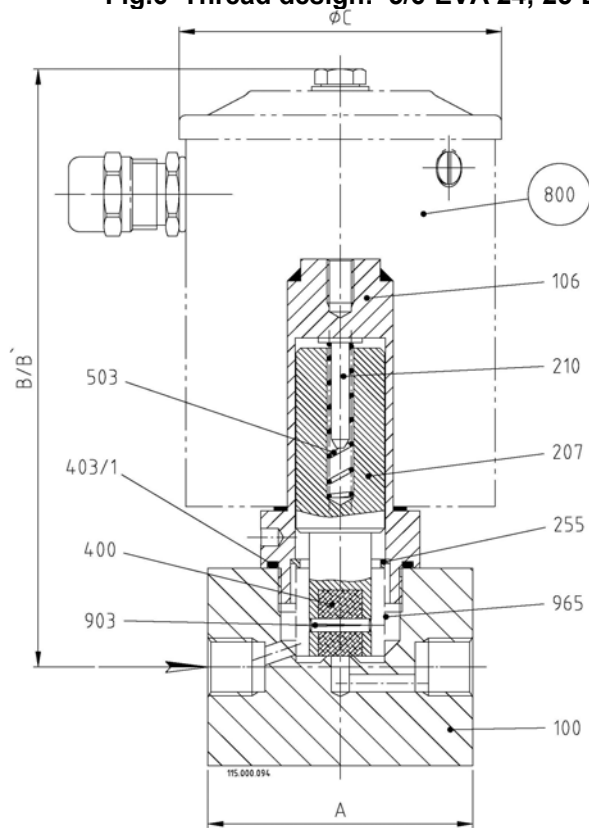
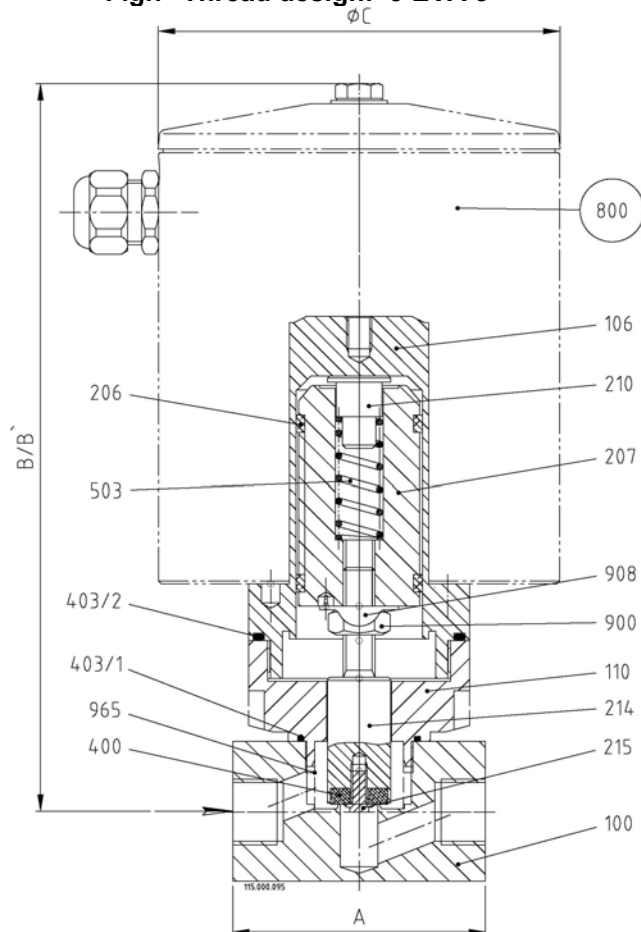

Fig.7 Thread design: 5-EVA 5



## 11.2 List of parts

Pos./ Item	Stück/ Qty.	Benennung	Description
100	1	Ventilgehäuse	Valve chamber
106	1	Gehäuseoberteil	Upper part of housing
108	1	Gehäuseflansch	Housing flange
110	1	Distanzstück	Spacer
200	1	Ventilteller	Valve disk
201	1	Tellerscheibe	Disc plate
202	1	Ventilstück	Valve piece
203	1	Federkappe	Spring cap
205	1	Ventilspindel	Valve spindle
206	2	Führungsring	Guide ring
207	1	Magnetkern	Magnet core
210	1/3	Federbolzen	Spring bolt
212	1	Spindelführung	Spindle guide
213	1	Gewinding	Threaded ring
214	1	Ventilstift	Valve pin
215	1	Tellerschraube	Plate screw
255	1	Führungsteil	Guide piece
400	1	Ventiltellerdichtung	Valve disc seal
402	1	Flachdichtung	Flat gasket
403/1	1	O-Ring	O-ring
403/2	1	O-Ring	O-ring
503	1/3	Druckfeder	Pressure spring
509	1	Distanzring	Distance ring
800	1	Magnetantrieb	Solenoid drive
900	4	Sechskantschraube	Hex. head screw
901	2	Sechskantmutter	Hex. nut
902	1/2	Bolzen	Bolt
903	1	Kerbstift	Cotter pin
905	4	Federring	Lock washer
906	1	Scheibe	Washer
908	1	Sicherungsblech	Safety plate
912	1	Splint	Split pin
943	1	Spannstift	Spring dowel sleeve
948	4	Nordlockscheibe	Safety disc
949	1	SL-Sicherung	SL-retainer
950	1	Kugel	Ball
965	1	Filtersieb	Filter sieve

### Wearing parts

Version	Fig.	Type	Spare parts
<b>Flange version</b>	Fig.1	02- EVA 5N - 200 05- EVA 5N - 200 1- EVA 20N - 125	Spare part kit (1), Solenoid drive (800)
	Fig.2	10/20- EVA 5N	Spare part kit (2), Solenoid drive (800)
<b>Thread version</b>	Fig.3	03- EVA 2	Solenoid drive (800)
	Fig.4	03- EVA 3-10 1- EVA 2-7	Solenoid drive (800)
	Fig.5	03-EVA 12-20 08-EVA 20 1-EVA 10-15	Spare part kit (3), Solenoid drive (800)
	Fig.6	5/6-EVA 24 25-EVA 23 40-EVA 23	Solenoid drive (800)
	Fig.7	5-EVA 5	Solenoid drive (800)

**Dimension with standard solenoid drive**

Connection G	Dimension	1/4	3/8	1/2	3/4	1	1 1/4	1 1/2	2
<b>Installation length</b>	<b>A</b>	60	80	80	95	105	120	150	170
03- EVA	<b>B</b>	80	133	133	152	159	183	251	268
	<b>B`</b>	140	200	200	220	226	263	346	372
	<b>ØC</b>	62	83	83	83	83	106	127	127
08- EVA	<b>B</b>	-	-	-	-	-	-	-	262
	<b>B`</b>	-	-	-	-	-	-	-	403
	<b>ØC</b>	-	-	-	-	-	-	-	153
1- EVA	<b>B</b>	134	134	134	172	277	235	288	-
	<b>B`</b>	200	200	200	252	372	339	415	-
	<b>ØC</b>	83	83	83	106	127	127	153	-
1- EVA 36	<b>B</b>	-	136	-	-	-	-	-	-
	<b>B`</b>	-	205	-	-	-	-	-	-
	<b>ØC</b>	-	83	-	-	-	-	-	-
1- EVA 56	<b>B</b>	-	-	136	-	-	-	-	-
	<b>B`</b>	-	-	205	-	-	-	-	-
	<b>ØC</b>	-	-	83	-	-	-	-	-
5- EVA24	<b>B</b>	136	-	-	-	-	-	-	-
	<b>B`</b>	205	-	-	-	-	-	-	-
	<b>ØC</b>	83	-	-	-	-	-	-	-
5- EVA 5	<b>B</b>	-	-	223	-	-	-	-	-
	<b>B`</b>	-	-	320	-	-	-	-	-
	<b>ØC</b>	-	-	127	-	-	-	-	-
6- EVA 24	<b>B</b>	136	-	-	-	-	-	-	-
	<b>B`</b>	205	-	-	-	-	-	-	-
	<b>ØC</b>	83	-	-	-	-	-	-	-
25- EVA 23	<b>B</b>	137	-	-	-	-	-	-	-
	<b>B`</b>	205	-	-	-	-	-	-	-
	<b>ØC</b>	83	-	-	-	-	-	-	-
40- EVA 23	<b>B</b>	137	-	-	-	-	-	-	-
	<b>B`</b>	205	-	-	-	-	-	-	-
	<b>ØC</b>	83	-	-	-	-	-	-	-

**Dimension with standard solenoid drive**

Flange DN	Dimension	15	20	25	32	40	50	65	80	100	125	150	200
<b>Installation length</b>	<b>A<sup>1)</sup></b>	130	150	160	180	200	230	290	310	350	400	480	600
Flange ANSI	Dimension	1/2"	3/4"	1"	1 1/4"	1 1/2"	2"	2 1/2"	3"	4"	-	6"	8"
<b>Installation length</b>	<b>A<sup>2)</sup></b>	108	118	127	140	165	203	216	241	292	-	406	495
02-EVA	<b>B</b>	236	236	236	249	290	346	352	381	400	425	448	565
	<b>B`</b>	316	316	316	330	395	473	493	540	560	584	607	754
	<b>ØC</b>	106	106	106	106	127	153	153	191	191	191	191	230
05-EVA	<b>B</b>	236	236	280	290	347	350	388	381	400	425	508	565
	<b>B`</b>	316	316	375	385	474	491	547	540	560	584	697	754
	<b>ØC</b>	106	106	127	127	153	153	191	191	191	191	230	230
1-EVA	<b>B</b>	-	-	-	-	-	350	388	381	400	425	-	-
	<b>B`</b>	-	-	-	-	-	491	547	540	560	584	-	-
	<b>ØC</b>	-	-	-	-	-	153	191	191	191	191	-	-
10- EVA	<b>B</b>	428	-	-	-	-	-	-	-	-	-	-	-
	<b>B`</b>	555	-	-	-	-	-	-	-	-	-	-	-
	<b>ØC</b>	153	-	-	-	-	-	-	-	-	-	-	-
20- EVA	<b>B</b>	428	-	-	-	-	-	-	-	-	-	-	-
	<b>B`</b>	569	-	-	-	-	-	-	-	-	-	-	-
	<b>ØC</b>	153	-	-	-	-	-	-	-	-	-	-	-

A<sup>1)</sup> = Dimension at DIN (resp. flanges ANSI and dimension DIN or flanges and dimension at DIN)

A<sup>2)</sup> = Dimension at ANSI 150lbs (resp. flanges and dimension at ANSI)  
B` = Dimension for removing the solenoid drive

## 12.0 Declaration of Conformity

 <p>UNI-Geräte E. Mangelmann Elektrotechnische Fabrik GmbH Postfach 1261 D – 47649 Weeze</p>	 <p><b>Konformitätserklärung</b> <i>Declaration of Conformity</i></p>	<p>Sicherheitsabsperventill <i>Safety shut-off valve</i></p> <p>Magnetventill <i>Solenoid Valve</i></p> <p>5-EVA 5-4</p> <p>Rp 1/2"</p> <p>90/396/EWG Gasgeräte-Richtlinie Gas Appliance Directive 2006/42/EG Maschinenrichtlinie Machinery Directive 2006/95/EG Niederspannungsrichtlinie Low-Voltage Directive 2004/108/EG EMV-Richtlinie EMC Directive</p> <p>DIN EN 161 DIN 3394-1 DIN EN 50021</p> <p>90/396/EWG Deutsche Vereinigung des Gas- und Wasserfaches e. V. (DVGW) Notified Body 0085</p> <p>90/396/EWG 2006/42/EG</p> <p>CE-0085AQ0219 CE</p> <p>Das Unternehmen UNI Geräte E. Mangelmann Elektrotechnische Fabrik GmbH bescheinigt hiermit, dass die o. a. Baureihe die grundsätzlichen Anforderungen der aufgeführten Richtlinien und Normen erfüllt. UNI Geräte E. Mangelmann Elektrotechnische Fabrik GmbH confirms that the basic requirements of the above specified directives and standards are fulfilled.</p> <p><b>Weeze, den 18.02.2008</b></p>  <p><b>Geschäftsführer</b> Managing Director</p>  <p><b>Leiter Konstruktion</b> Head of Design</p>
 <p>UNI-Geräte E. Mangelmann Elektrotechnische Fabrik GmbH Postfach 1261 D – 47649 Weeze</p>	 <p><b>Konformitätserklärung</b> <i>Declaration of Conformity</i></p>	<p>Sicherheitsabsperventill <i>Safety shut-off valve</i></p> <p>Magnetventill <i>Solenoid Valve</i></p> <p>...EVA...-4 ...</p> <p>Rp 1/2" – Rp 2", DN 15 – DN 200</p> <p>90/396/EWG Gasgeräte-Richtlinie Gas Appliance Directive 2006/42/EG Maschinenrichtlinie Machinery Directive 2006/95/EG Druckgeräterichtlinie Pressure Equipment Directive 2004/108/EG EMV-Richtlinie EMC Directive</p> <p>DIN EN 161 AD 2000 DIN EN 50021</p> <p>90/396/EWG Deutsche Vereinigung des Gas- und Wasserfaches e. V. (DVGW) Notified Body 0085</p> <p>90/396/EWG 2006/42/EG 97/23/EG<sup>1)</sup> ≥ DN 125</p> <p>CE-0085AQ0563 CE CE 0062</p> <p>Das Unternehmen UNI Geräte E. Mangelmann Elektrotechnische Fabrik GmbH bescheinigt hiermit, dass die o. a. Baureihe die grundsätzlichen Anforderungen der aufgeführten Richtlinien und Normen erfüllt. UNI Geräte E. Mangelmann Elektrotechnische Fabrik GmbH confirms that the basic requirements of the above specified directives and standards are fulfilled.</p> <p><b>Weeze, den 18.02.2008</b></p>  <p><b>Geschäftsführer</b> Managing Director</p>  <p><b>Leiter Konstruktion</b> Head of Design</p>

<sup>1)</sup> Nicht aufgeführte Nennweiten fallen nicht in den Anwendungsbereich der 97/23/EG  
Sizes not mentioned are not included in the EC-Directive 97/23/EG



UNI-Geräte E. Mangelmann  
Elektrotechnische Fabrik GmbH  
Postfach 1261  
D – 47649 Weeze



**Konformitätserklärung**  
*Declaration of Conformity*

**Produkt**  
*Product*  
Sicherheitsabsperventil  
*Safety shut-off valve*

**Handelsbezeichnung**  
*Trade Mark*  
Magnetventil  
*Solenoid Valve*

**Baureihe**  
*Series*  
25-EVA 23-4

**Nennweite**  
*Size*  
Rp 1/4"

**EU-Richtlinien**  
*EC-Directives*  
90/396/EWG Gasgeräterichtlinie *Gas Appliance Directive*  
2006/42/EG Maschinrichtlinie *Machinery Directive*  
2006/95/EG Niederspannungsrichtlinie *Low-Voltage Directive*  
2004/108/EG EMV-Richtlinie *EMC Directive*

**Angewandte technische Spezifikation**  
*Applied Technical Specification*  
DIN 3394-1

**EG-Baumusterprüfung**  
*EC-Type Examination*  
90/396/EWG Deutsche Vereinigung des Gas- und Wasserfaches e.V. (DVGW)  
Notified Body 0085

**Überwachungsverfahren**  
*Surveillance Procedure*  
90/396/EWG Deutsche Vereinigung des Gas- und Wasserfaches e.V. (DVGW)  
Notified Body 0085

**Kennzeichnung**  
*Marking*  
CE  
CE-0085AT0196

Das Unternehmen UNI Geräte E. Mangelmann Elektrotechnische Fabrik GmbH bescheinigt hiermit, dass die o.a. Baureihe die grundsätzlichen Anforderungen der aufgeführten Richtlinien und Normen erfüllt.  
*UNI Geräte E. Mangelmann Elektrotechnische Fabrik GmbH confirms that the basic requirements of the above specified directives and standards are fulfilled.*

Weeze, den 18.02.2008

  
Geschäftsführer  
Managing Director

  
Leiter Konstruktion  
Head of Design

250.000.117-02



UNI-Geräte E. Mangelmann  
Elektrotechnische Fabrik GmbH  
Postfach 1261  
D – 47649 Weeze



**Konformitätserklärung**  
*Declaration of Conformity*

**Produkt**  
*Product*  
Sicherheitsabsperventil  
*Safety shut-off valve*

**Handelsbezeichnung**  
*Trade Mark*  
Magnetventil  
*Solenoid Valve*

**Baureihe**  
*Series*  
40-EVA 23-4

**Nennweite**  
*Size*  
Rp 1/4"

**EU-Richtlinien**  
*EC-Directives*  
90/396/EWG Gasgeräterichtlinie *Gas Appliance Directive*  
2006/42/EG Maschinrichtlinie *Machinery Directive*  
2006/95/EG Niederspannungsrichtlinie *Low-Voltage Directive*  
2004/108/EG EMV-Richtlinie *EMC Directive*

**Angewandte technische Spezifikation**  
*Applied Technical Specification*  
DIN 3394-1  
DIN EN 50021

**EG-Baumusterprüfung**  
*EC-Type Examination*  
90/396/EWG Deutsche Vereinigung des Gas- und Wasserfaches e.V. (DVGW)  
Notified Body 0085

**Überwachungsverfahren**  
*Surveillance Procedure*  
90/396/EWG Deutsche Vereinigung des Gas- und Wasserfaches e.V. (DVGW)  
Notified Body 0085

**Kennzeichnung**  
*Marking*  
CE  
CE-0085AQ0726

Das Unternehmen UNI Geräte E. Mangelmann Elektrotechnische Fabrik GmbH bescheinigt hiermit, dass die o.a. Baureihe die grundsätzlichen Anforderungen der aufgeführten Richtlinien und Normen erfüllt.  
*UNI Geräte E. Mangelmann Elektrotechnische Fabrik GmbH confirms that the basic requirements of the above specified directives and standards are fulfilled.*

Weeze, den 18.02.2008

  
Geschäftsführer  
Managing Director

  
Leiter Konstruktion  
Head of Design

250.000.093-02



UNI-Geräte E. Mangelmann  
Elektrotechnische Fabrik GmbH  
Postfach 1261  
D-47649 Weeze



**Konformitätserklärung**  
*Declaration of Conformity*

**Produkt**  
*Product*  
Sicherheitsabsperventil  
*Safety shut-off valve*

**Handelsbezeichnung**  
*Trade Mark*  
Magnetventil  
*Solenoid Valve*

**Baureihe**  
*Series*  
10-EVA 5N-4..., 20-EVA 5N-4...

**Nennweite**  
*Size*  
DN 15

**EU-Richtlinien**  
*EC-Directives*  
90/396/EWG Gasgeräte Richtlinie Gas Appliance Directive  
2006/42/EG Maschinenrichtlinie Machinery Directive  
2006/95/EG Niederspannungsrichtlinie Low-Voltage Directive  
2004/108/EG EMV-Richtlinie EMC Directive

**Angewandte technische Spezifikation**  
*Applied Technical Specification*  
DIN 3394  
DIN EN 50021

**EG-Baumusterprüfung**  
*EC-Type Examination*  
90/396/EWG Deutsche Vereinigung des Gas- und Wasserfaches e.V. (DVGW)  
Notified Body 0085

**Überwachungsverfahren**  
*Surveillance Procedure*  
90/396/EWG Deutsche Vereinigung des Gas- und Wasserfaches e.V. (DVGW)  
Notified Body 0085

**Kennzeichnung**  
*Marking*  
90/396/EWG CE-0085AQ0409  
2006/42/EG CE

Das Unternehmen UNI Geräte E. Mangelmann Elektrotechnische Fabrik GmbH bescheinigt hiermit, dass die o.a. Baureihe die grundsätzlichen Anforderungen der aufgeführten Richtlinien und Normen erfüllt.  
UNI Geräte E. Mangelmann Elektrotechnische Fabrik GmbH confirms that the basic requirements of the above specified directives and standards are fulfilled.

Weeze, den 18.02.2008

  
Geschäftsführer  
Managing Director

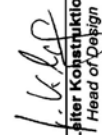
  
Leiter Konstruktion  
Head of Design

