

Operating and mounting manual

Safety shut off valve

gas – pneumatic valve

10 – 4 EPVA and 40 – 4 EPVA

Contents

- 1.0 General remarks**
 - 1.1 Valve data
 - 1.2 Application
- 2.0 Danger Notices**
 - 2.1 Safety terms
 - 2.2 Safety notice
 - 2.3 Qualified staff
 - 2.4 Unauthorized modification and spare part production
 - 2.5 Unauthorized operation
 - 2.6 Safety information for the use in explosion-prone areas guideline 94/9/EC
- 3.0 Handling**
 - 3.1 Transport
 - 3.2 Storage
 - 3.3 Handling before mounting
- 4.0 Product Description**
 - 4.1 Function
 - 4.2 Technical Data
 - 4.3 Marking
- 5.0 Installation**
 - 5.1 Warning of Dangers during Installation, Operation and Maintenance
 - 5.2 Installation
- 6.0 Operation**
 - 6.1 Commissioning
 - 6.2 Shutting down
 - 6.3 Maintenance
 - 6.4 Putting back into Operating
- 7.0 Troubleshooting**
 - 7.1 Detection of defects
 - 7.2 Troubleshooting Plan
- 8.0 Dismantling of the Valve**
 - 8.1 Visual inspection
 - 8.2 Replacement of Wear Parts
- 9.0 Warranty**
- 10.0 Explanations on Codes and Directives**
- 11.0 Drawing**
 - 11.1 Sectional drawing
 - 11.2 Projection
 - 11.3 Control valve
 - 11.4 List of parts
- 12.0 Declaration of Conformity**

1.0 General remarks

This operating manual includes instructions to assemble and operate the valve in the prescribed and safe way. **Additionally and accordance with the solenoid drive of the control valve (805), the relevant manufacturer's operating instructions (BTA) must be taken into consideration.**

If any difficulties appear that can not be solved by means of the operating manual, further information may be demanded from the manufacturer.

This operating manual is in accordance with the relevant valid EN safety standards and the valid prescriptions and rules of the Federal Republic of Germany.

If the solenoids are used abroad of the FRG, the operator and/or the person who is responsible for the plant concept must take care that the valid national rules are met.

The manufacturer reserves the right of any technical change and improvement.

The use of these operating instructions suppose the qualification of the user according to paragraph 2.3 "qualified staff".

The operating staff must be trained in accordance with the operating instructions. The operating manual must always be available at the location where used.

1.1 Valve instruction

Manufacturer:

UNI Geräte E. Mangelmann
Elektrotechnische Fabrik GmbH
Holtumsweg 13
D-47652 Weeze
Telefon: +49 (0) 2837/9134-0
Fax: +49 (0) 2837/1444
E-Mail: info@uni-geraete.de
Homepage: www.uni-geraete.de

Designation

Directly functioning, currentless closed, spring safety shut off valve with pneumatic drive.

Type test acc. to 90/396/EEC

DIN EN 161 Kl. A, Gr. 2

DIN 3394-1 Gr. A

Working pressure 10-4-EPVA 10bar
40-4-EPVA 40bar

Ambient temperature: -20°C bis + 60°C

Medium temperature: -20°C bis + 60°C

Fitting position: vertical or horizontal drive.

Switching cycles: 1000 cycles/h

Flange connection measures acc. to DIN EN 1092-2

Flange DN	PN	Prod. Id.	40	50	65	80	100	150	200	250	300	Design pressure PS = PN
10-4-EPVA	16	CE-0085AS0514	-	-	-	-	-	X	X	X	X	PN 16
40-4-EPVA	40	CE-0085AQ0725	X	X	X	X	X	-	-	-	-	PN 40

X Type test acc. To 90/396/EEC, O Acceptance test certificate 3.1 C possible, - not available,

Control medium: Air, nitrogen -20°C up to + 60°C

Control pressure: Min. –control pressure, second number on the type plate
Max. –control pressure 4-10bar

Electric connection control valve: Notice instructions on type plate of control valve.

1.2 Application

The UNI Geräte gas – pneumatic valve 10-4-EPVA and 40-4-EPVA are used as automatic safety shut off valves to secure, to limit, shut-off and release gas and air supply at main shut-off devices or in front of gas burners e.g. acc. to DIN EN 746-2.

The valves are suitable for gases of the 1st, 2nd and 3rd gas families to G260 and for neutral gases and as a variant with material design for aggressive gases such as e.g. biogas, sewage plant gas or dump gas to G262.

If used in other cases, the operator must carefully check if construction/design of valve, accessories and materials are suitable for the new application. The range of application is subject to the responsibility of the plant planner. The service life of the valve is 20 years.

2.0 Danger Notices

2.1 Safety Terms

The signal terms DANGER, CAUTION und NOTICE are used in this operating manual in case of notices concerning special dangers, or for unusual information, requiring a special marking.



DANGER! means that in case of non-observance there is danger to life and/or considerable damage.



CAUTION! means that in case of non-observance there is danger of injury and/or damage.



NOTICE! means that attention is drawn to technical correlations/connections.

Observance of other, not especially marked notices concerning transport, assembly, operation and maintenance and other data (in the operating manual, product documentation and at the unit itself) is also essential, in order to avoid disturbances that might affect direct or indirect damage to property or injury to persons.

2.2 Safety Notice

Non observance of safety instructions can lead to loss of any claim for damages.

Non observance can lead to the following mentioned dangers:

- Failure of important functions of the valve/plant
- Endangering of persons by electrical or mechanical influences.
- Protection against accidental contact for moving parts may not be removed as long as the valve is in operation.
- Leakage of dangerous media (e.g. explosive, toxic, hot) must be removed in the way that there is no danger for persons or environment. Laws and regulations must be observed.

2.3 Qualified Personnel

These are persons who are familiar with erection, assembly, starting, operation and maintenance of the product and who have special qualifications acc. to their activities and functions, e.g.:

- Instruction and obligation to carry out and meet all regional and in-house orders and requirements.
- Education or instruction according to the safety engineering standards in use and maintenance of adequate safety and working protection equipment.
- Training in first aid.

2.4 Unauthorized Modification and Spare Part Production

Modification or changes of the valve are only allowed after agreement of the manufacturer. Original drawings and accessories authorized by the manufacturer are for safety purposes. The use of other parts or unauthorized constructive changes at the valve by third persons may cancel and abolish the manufacturer's liability for resulting consequences.

2.5 Unauthorized Operation

Operational reliability of the delivered valve is only guaranteed in case of determined use in accordance to paragraph 1 of the operating manual. **The application limits mentioned on the type sign may on no account be exceeded.**

2.6 Safety information for the use in explosion-prone areas guideline 94/9/EC

- The temperature of the medium must not exceed the respective temperature class, and respectively, the respective maximum permitted medium temperature as per operation guideline.
- If the valve is heated (e.g. heating jacket), care must be taken, that the specified temperature class is kept in the time.
- The valve must be connected to the ground.
In the case most simple this can be realized via pipe screws by means of tooth disc. Otherwise the connection to the ground must be implemented by other measures e.g. cable links.
- Control valves, electrical and electrical/mechanical drives as well as sensors must undergo a separate conformity check as per ATEX. In doing so the respective safety and explosion protection information in the operation instructions are to taken into special consideration.

Furthermore we point out the guideline 95/C332/06(ATEX 118a), which include the minimum regulations for the improvement of the health-related situation and the safety of the employees, who might be jeopardized by an explosive atmosphere.

3.0 Handling

3.1 Transport

For any transport works, the generally recognised technical rules and standards as well as rules for prevention of accidents must be observed.

In case of transport, storage and stopping, the flange protection caps must be mounted at both valve flanges.

The goods to be transported must be carefully treated. During transport, the valve must be protected against strokes, impacts or vibration. The coat of lacquer may not be damaged. Transport temperature is -20°C up to $+60^{\circ}\text{C}$.

Never transport the valve at pneumatic drive piping/ tubing or components. Transport the valve at provided transport angles (256) from KA120 or ring nut (926) from KA160.

Transport the valve in a box or on a pallet with soft base and it smoothly on even floor. **Never put valve on the piping/ tubing or its components.**

The goods must be checked on completeness and transport damage. See also section 9.0

3.2 Storage

If the valve is not installed immediately after delivery, it must be stored properly.

- Storage temperature -20°C up to $+60^{\circ}\text{C}$, dry and clean.
- The lacquer protects against corrosion in neutral dry atmosphere. Do not damage colour.
- In humid rooms, a drying agent or a heating resp. is necessary because of condensation of water.

Requirements according to DIN 7716 (products made of caoutchouc and rubber) must be met.

3.3 Handling before Assembly

- In case of valve with protection caps, they must be removed before being mounted!
- Protect against atmospheric influences such as humidity (otherwise use drying agent).
- Appropriate treatment protects against damage.

4.0 Product description

The UNI-Geräte gas-pneumatic valves 10-4 EPVA and 40-4 EPVA are a directly controlled, currently-closed, quickly closing safety shut-off valve acc. to DIN EN 13611, DIN 3394-1 and DIN EN 161 with pneumatic drive.

The drive is actuated by a 3/2 way control valve with solenoid drive, type 10-EVD 2 or 10-EVD 2/2401 resp.

The sectional drawing part 11.1 in Fig. 1 and 2 shows the valve construction.

4.1 Function

When opening the 3/2 way control valve (805) the control medium flows via the connection 3 → 2 under the drive piston (217). The control medium pushes the drive piston (217) against the pressure spring (503) and opens- via the valve spindle (205)- the balance piston (220) that is pressure impinged. The valve is open.

The valve closes in case of shut-off, failure or interruption of power energy to control valve (805). The compressed control valve in the pneumatic drive is blown-off via the quick-venting mechanism (601) with sound absorber (600) and the control valve (805).

4.2 Technical Data

Opening times: 0,8 – 2s, depends upon nominal width

Closing times: < 1s

Drive types and air consumption in standard litre (NL) per connection at 4 bar control pressure.

Flange DN	40	50	65	80	100	150	200	250	300
10-4-EPVA....	-	-	-	-	-	KA 120 5NL	KA 160 10NL	KA 160 10NL	KA 200 17NL
40-4-EPVA...	KA 120 2,5NL	KA 160 4,5NL	KA 160 4,5NL	KA 160 4,5NL	KA 200 9,0NL	-	-	-	-

Air consumption for 10 bar, multiply control pressure table values by 2,2.

Max. valve loading by pipe power to DIN EN 161

The indicated moments may not work longer than 10s.

DN		40	50	65	80	100	125	≥150
Torsion	Nm	200	250 ¹⁾	325 ¹⁾	400 ¹⁾	-	-	-
Bending	Nm	610	1100	1600	2400	5000	6000	7600

¹⁾ Not valid in case of valves with flanges

Starting torque, pipe screws greased

DN		40	50	65	80	100	125	≥150
Torque	Nm	50	50	50	50	80	160	160

Starting torque, product screws and nuts greased

Screw		M6	M8	M10	M12	M16	M20	M24
Torque	Nm	5	11	22	39	70	110	150

4.3 Marking

The type sign on the pneumatic drive has the following information:

- Fabricator
- Valve type, nominal width, pressure and temperature indication, fitting position
- Year of construction/ production no.
- Product ID No. to 90/396/EEC
- Valve class and valve group acc. to DIN EN 161, DIN 3394-1
- CE-sign and no. of relevant location to 97/23/EC
- Fluid group and test pressure PT to 97/23/EC
- Pneumatic drive type
- Control medium, p_{min} and p_{max} for control medium.

Refer also to section 10.0.

5.0 Installation

5.1 Warning of Dangers during Installation, Operation and Maintenance



DANGER!

Safe operation of the valve can only be guaranteed if it is installed, commissioned and maintained by qualified personnel (see point 2.3 “Qualified staff”) correctly and in observance of the warnings in this operating manual. Apart from that, the operation safety order and the qualified use of tools and protection equipment must be guaranteed. The operating instructions for the valve must be observed during all work on or with the valve. Failure to observe these instructions may result in injury or in damage to the valve or other installations.

When the valve is used as a final sealing element, a safety precaution e.g. blanking disc, blind flange, etc., in accordance with the code of practice of the German Technical and Scientific Association for Gas and Water (DVGW) is recommended during all repair work.

5.2 Installation

Apart from the general installation guidelines, the following points should be observed:



NOTICE!

- Remove the flange covers.
- The inside of the valve and the pipeline must be free from foreign particles.
- Observe the installation position in relation to the flow direction, see markings on the valve.
- Centre gaskets between the flanges.
- The connecting flanges must be aligned.
- Ensure that none of the components is strained during installation.
- The valve must not be used as a fixed point; it is supported by the pipework system.
- Protect valves from soiling, particularly during construction work.
- Thermal expansion of the pipework must be equalized using compensators.

In accordance with DIN 3394-1 and DIN EN 161, a dirt trap must be installed upline of any safety shut-off device. The mesh size of the screen must be smaller than 1.5 mm and not allow a test mandrel of 1 mm diameter to pass. Where two safety shut-off devices are combined to form a group, one dirt trap installed upstream of the first valve is sufficient. The dirt trap must be installed not too far upline of the first valve. The UNI-Geräte dirt traps of the SF / SFR Series are approved for use together with the gas pneumatic valves in accordance with 90/396/ECE.

The valve can be installed with vertical or horizontal pneumatic drive. The solenoid drive of the control valve should preferably be installed with vertical drive. The control air must be connected at connection 3. We recommend an air filter in front of the control valve. Mesh size 40 ym.



NOTICE!

Please observe the control valve operating instructions (BTA).

6.0 Operation



DANGER!

Before commissioning a new installation or before starting up an installation again after repairs or modifications, ensure:

- The proper completion of all installation and assembly work!
- Commissioning only by “qualified staff” (see point 2.3).
- Installation or repair of existing guards and protection equipment.

6.1 Commissioning

- Before commissioning, check the data on material, pressure, temperature and flow direction with the layout plan of the pipework system.
- Depending on the field of application, the local regulations have to be observed, e.g. the operation safety order.
- Residues in the pipework and the valve (dirt, weld beads, etc.) will inevitably result in leaks.
- Leakage inspection of the installed valve.

6.2 Shutting Down

- Depending on the field of application, the local regulations have to be observed, e.g. the operation safety order.

6.3 Maintenance

Gas – pneumatic valves have to be checked at regular intervals for proper function and internal leak tightness. The intervals for regular inspections have to be defined by the operator according to the operating conditions. UNI-Geräte recommends an internal visual inspection once a year and an overhaul of the valve after 2 years or after the following number of switching cycles at the latest:

Application temperature	≤ DN 25	≤ DN 80	≤ DN 150	> DN 150
≤ 25°C	150 000	75 000	25 000	20 000
> 25°C	50 000	25 000	25 000	5 000

6.4 Putting Back into Operation

When putting a valve back into operation, ensure that all the necessary steps described in section 5.2 (Installation) and section 6.1 (Commissioning) are repeated.

7.0 Troubleshooting

7.1 Detection of defects



DANGER!

Be sure to observe the safety instructions during troubleshooting.

If the malfunctions cannot be remedied using the following “**Troubleshooting plan (7.2)**” please contact the manufacturer.

In the event of faults in the function or operating behaviour of the valve, check whether the installation work was carried out and completed as described in this operating manual. Depending on the field of application, the operation safety order must be observed.

Check the data on material, pressure, temperature, voltage and flow direction with the layout plan of the pipework system. In addition, check whether the operating conditions correspond to the technical data in the data sheet or on the rating plate.

7.2 Troubleshooting plan

Malfunction	Possible causes	Remedy
No flow	Pneumatic drive does not open	Switch on control valve (805) Check control pressure Clean filter control line, if necessary
	Working pressure too high	Compare working pressure with the data on the rating plate
	Flange covers were not removed	Remove flange covers

Malfunction	Possible causes	Remedy
Low flow rate	verunreinigter Schmutzfänger	Clean / exchange sieve
	Clogging in the pipework system	Check pipework system
Valve leaking at seat, no internal tightness	Valve seat gasket (400) or valve seat (100) damaged by external particles	See section 8 or replace valve
No external tightness	Gaskets damaged	See section 8 or replace valve
Valve opens too slowly	Ventilation boring in spring cap (112) closed	Open boring
	Control pressure too low	Check control pressure
Valve closes too slowly	Dirt in control line	Clean sound absorber (600) Clean vent line
	Reduced conductor cross sections	Replace folded control lines
Valve does not close	Control valve does not close	Check, if residual voltage is aligned
	Dirt in control line	Clean sound absorber (600) Clean vent line
	Reduced conductor cross sections	Replace folded control lines
Flange fracture (valve/ pipework)	Screws not tightened uniformly, mating flanges not aligned	Align pipework. Install new valve



NOTICE!

Observe section 10.0 before all installation and repair work!

Observe section 6.4 when putting the valve back into operation!

8.0 Dismantling of the Valve

In addition to the general installation guidelines and the operation safety order, the following points must also be observed:



DANGER!

- Depressurised pipework system
- Cooled medium
- Emptied installation
- Vent pipework systems containing corrosive, inflammable, aggressive or toxic media
- Have dismantling work carried out only by qualified staff (see point 2.3)

8.1 Visual inspection

Shut down the valve as described in section 6.2.

Switch off control valve (805) and disassemble the control line from pneumatic drive. Assemble a shut-off valve in the drive connection. Put control medium within the permissible pressure range on the pneumatic drive. Close shut-off valve. The valve is open. Loosen the hex. screw (900) resp. hex. nut (901/4). Disassemble the drive together with the balance piston (220).

During the visual inspection, pay attention to the following points:

1. Damage to the valve seat (100).
2. Damage to the valve disc sealing (400)
3. Soiling or foreign particles in the valve housing (100)
4. Residues in sound absorber(600/2)

When the valve seat is damaged, replace the valve chamber (100). When the valve disk sealing (400) is damaged, replace the balance piston completely (220). Remove contamination in the valve chamber (100). Clean sound absorber (600/2) at quick venting mechanism (601) and control valve (805).



CAUTION!

Before installation of the O-rings (403/5/6) grease groove in piston guide, and respectively, flat gasket in valve chamber with lubricant N32 or equivalent material (DVGW-authorization). Replace O-rings (403/5/6), and respectively, flat gasket, install properly and do not damage during installation.

Assemble the valve in the reverse order to the dismantling.

Examine the valve for internal and external leaks in accordance with DIN 3394-1 and finally carry out a function test.

8.2 Replacement of Wear Parts

Shut down the valve as described in section 6.2.

Remove complete drive in accordance with section 8.1



DANGER!

Opening of pneumatic drive

Spring cap is under spring tension. At least, two studs (236) must be permanently screwed in the spring cap.

Open shut-off valve and unscrew it. Remove two opposite and replace by threaded rods (see table)

Drive size	KA 70	KA 120	KA 160	KA 200	KA250
Threaded rod	M6 x 250	M10 x 450	M12 x 450	M16 x 500	M20 x 750

Before loosening the two last nuts (901/2), tighten the nuts at the threaded rods hand-tightly. Loosen the studs (236) together with the nuts (901/2) and remove them. Then loosen and remove the nuts of the threaded rods.



NOTICE!

First, the spring cap (112) is pressed against the nuts of the threaded rod.

Remove threaded rods and spring cap (112). Disassemble spring guide (204), pressure springs (503/1; (503/2) and pneumatic cylinder (111). Loosen nut (901/3). Remove spring disc (216), drive piston (217 and sealing piece (226).

Pull piston guide (221) and balance piston (220) with valve spindle (205) out of the spindle guide (212).



NOTICE!

By 10-4 EPVA / 40-4 EPVA DN80/100

Loosen hex. socket screw (910) and separate spacer (110) from housing flange (108). Pull off spindle guide (212).

All parts, marked as wearing part must be replaced. When the valve disk sealing (400) is damaged, replace the balance piston completely (220).

10-4 EPVA

De-installation of balance piston (220)

Drive out spring dowel sleeve (943) resp. from DN 200 loosen setscrew (943/1) and loosen and remove hex nut (901/1). Pull off disc plate (201) and balance piston (220) from the valve disc mounting (241).

Loosen setscrew (941/2) before de-installation of valve spindle (205).

The valve spindle (205) is de-installed by loosening of the spindle nut (219). Check the valve spindle (205) for scoring and replace it if necessary.



NOTICE!

Two-piece ring (218) falls out.

40-4 EPVA DN40/50/65

De-installation of balance piston (220)

Unscrew plate screw (215) of balance piston (220).

40-4 EPVA DN80/100

De-installation of balance piston (220)

Drive out spring dowel sleeve (943), loosen hex nut (901/1) and remove with disc plate (201).

The valve spindle (205) is de-installed by loosening of the spindle nut (219). Check the valve spindle (205) for scoring and replace it if necessary.



NOTICE!

Two-piece ring (218) falls out.

Assemble the valve in the reverse order to the dismantling.



DANGER!

10-4 EPVA

After pulling off of the hex. nut (901/1) pin together the valve disc mounting (241) with the hex nut (901/1) by means of spring dowel sleeve (943), If necessary the bore for the spring dowel sleeve (943), resp. from DN 200 loosen setscrew (943/1), must be drilled. Up to three bores may be drilled into the valve disc mounting.



DANGER!

40-4 EPVA

After pulling off of the hex nut (901/1), pin together balance piston (220) with the hex. nut (901/1) by means of spring dowel sleeve (943) If necessary the bore for the spring dowel sleeve (943) must be drilled. Up to three bores may be drilled into the valve disc mounting.

Glue the spindle nut (219) with Loctite 245 or equivalent material.

Grease the balance piston (220), the valve spindle (205) in the area of the radial packing ring (404) and the valve spindle in the area of the two-piece ring (218) with lubricant Staburags N32 or equivalent material (DVGW-authorization).

Grease the pneumatic cylinder (111) in the area of the drive piston (217) with lubricant Staburags NBU 30.



CAUTION!

Install wear parts carefully and properly and do not damage them during assembly.

Examine the valve for internal and external leaks in accordance with DIN 3394-1 and finally carry out a function test.

9.0 Warranty

Scope and period of the warranty is specified in the edition of the “General Terms of Business of the UNI-Geräte E. Mangelmann Elektrotechnische Fabrik GmbH” valid at the time of delivery or else in the purchase agreement.

We warranty that the valve is free from faults in line with the state of the art and for the confirmed field of application.

No warranty claims will be accepted for damage resulting from improper use or failure to observe these operating and installation instructions, the statutory accident prevention regulations, the EN, DIN and VDE standards and other codes and regulations.

Warranty claims will also not be accepted for damage occurring during operation due to operating conditions deviating from those specified in the data sheet or in other agreements.

Justified complaints will be remedied by reworking by us or specialist companies authorized by us.

Claims going beyond the scope of the warranty will not be accepted. The customer shall have no right to the supply of a replacement valve.

Maintenance work, installation of parts from other manufacturers, any modifications to the design and natural wear are not covered by the warranty.

Transport damage must be reported not to us but **without delay** to your responsible goods handling company, the railway company or the shipping agent as otherwise all claims for damages against these companies will be voided.

10.0 Explanation on Codes and Directives

The Commission of the European Union has laid down common directives for the free trading of goods within the Union specifying minimum requirements for safety and health protection. The CE symbol confirms that products comply with the EU directives, i.e. in conformity with the relevant, in particular harmonised standards. Directives 90/396/EEC, 98/37/EC and 97/23/EC are of relevance for the gas pneumatic valve (mechanical part).

Notes on Directive 90/396/EEC (Appliances Burning Gaseous Fuels):

The valves have been developed, manufactured and tested in accordance with harmonised standard DIN EN 161 (DIN 3394-1, DIN 3391) and comply with the relevant requirements of the Union Directive 90/396/EEC. Unless otherwise stated separately, this has been confirmed by a type test.

Notes on Directive 98/37/EC (Machinery Directive):

The valves have been developed, manufactured and tested in accordance with Directive 98/37/EC.

Notes on Directive 97/23/EG (Pressure Equipment Directive, DGRL):

It has been conformed that the quality assurance in design control, manufacture and final acceptance of the manufacturer, UNI-Geräte E. Mangelmann Elektrotechnische Fabrik GmbH, satisfy the requirements of 98/23/EC Annex III Module H. The gas pneumatic valves comply with the fundamental requirements of Directive 97/23/EC. Valves with permissible working pressures ≤ 0.5 bar, DN ≤ 25 and all products certified in accordance with category I and with 94/396/EEC are not covered by 97/23/EC. Only products covered by DGRL and classified in category I or higher may be marked in accordance with 97/23/EC. Fluid group 1 includes explosive, inflammable and toxic media. Fluid group 2 includes media not belonging to fluid group 1.

The control valve (805) with solenoid drive comply with the directives 73/23/EC and 89/336/ECE.

Notes on Directive 73/23/EC (Low Voltage Directive):

The drives have been developed, designed and manufactured in accordance with standard “Electromagnetic Devices” DIN EDV 0580. The requirements of the Low Voltage Directive that is applicable for rated voltages from 50 to 1000 V AC and 75 to 1500 V DC are therefore also satisfied.

Note on Directive 89/336/EEC (EMC Directive):

The solenoids satisfy the requirements of the technical standard on interference emission (EN50081-1) and for interference suppression (EN 50082-2) for both the industrial sector and in the residential, business and commercial sector and in small companies.

When using AC and DC versions, the user must provide a suitable mains filter (e.g. X capacitor 47 nF) at the connection to the mains power supply in order to suppress the physical mains-borne turn-off interference of the solenoid coil.

Solenoid drives as drive elements for valves do not represent independently operated devices in the sense of the EMC Directive and are only further processed by specialist companies or are installed in a machine. Commissioning is not permitted until it has been determined that the whole machine or plant complies with the provisions of the EMC Directive.

Note concerning ex-guideline 94/9/EC (explosion guideline ATEX):

The product is not subject to guideline 94/9/EC, since due to the loads occurring during practical operation, there is no effective source of ignition even in case of an error case to be assumed. This also applies for spring-loaded components, like for example the pneumatic drive. In case of electric drives, sensors or other electric components the application as per 94/9/EC is to be checked separately.

National Codes and Directives

For the use of safety shut-off devices in accordance with DIN EN 12952-8 or DIN EN 746, the requirements of DIN EN 161 and DIN 3394-1 have to be satisfied. This is confirmed by a type test or by an acceptance test certificate to EN10204-3.1C.

11.0 Drawing

11.1 Fig.1 sectional drawing 10-4 EPVA

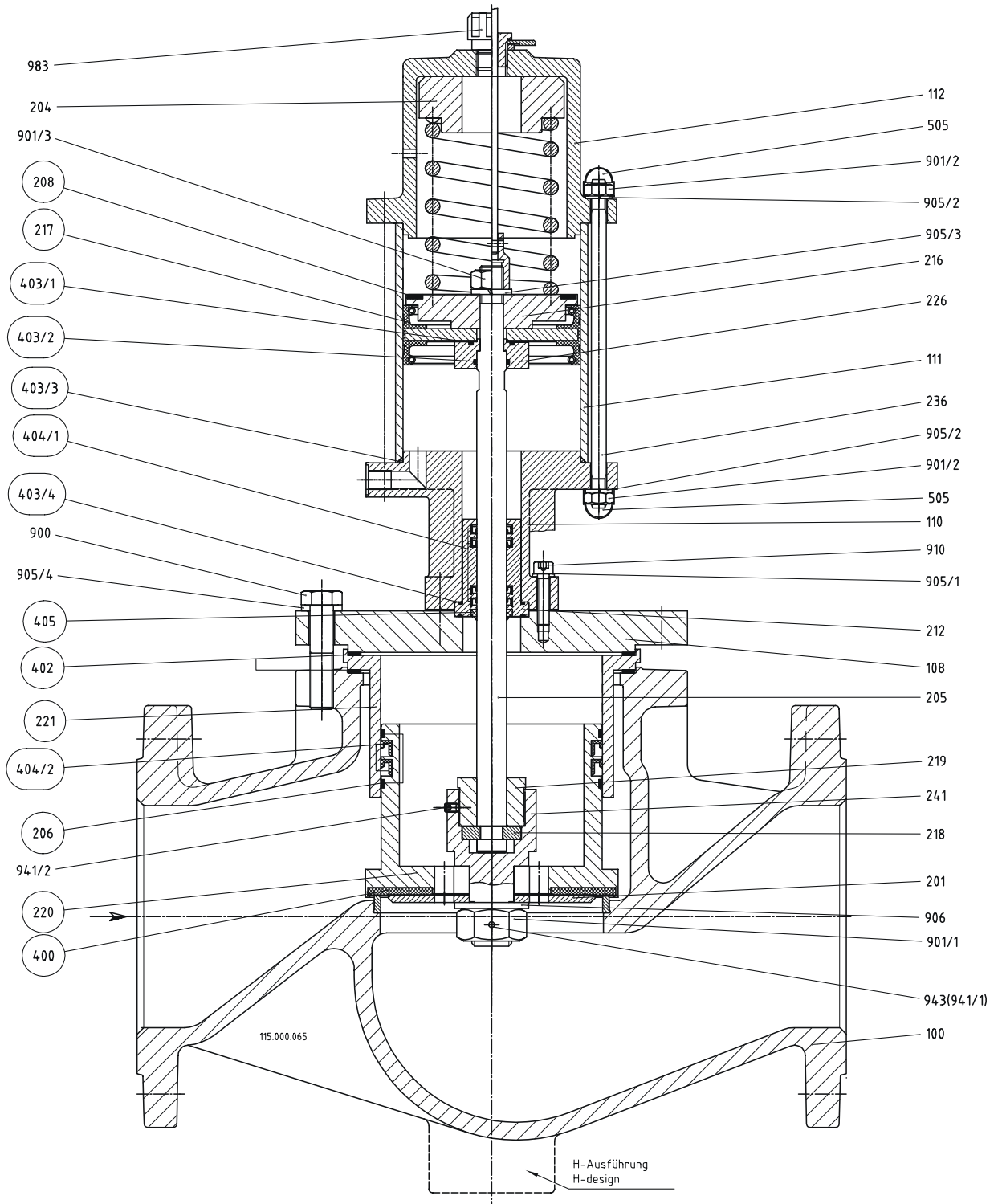

O = Wearing parts

Fig.2 sectional drawing 40-4 EPVA DN80/100

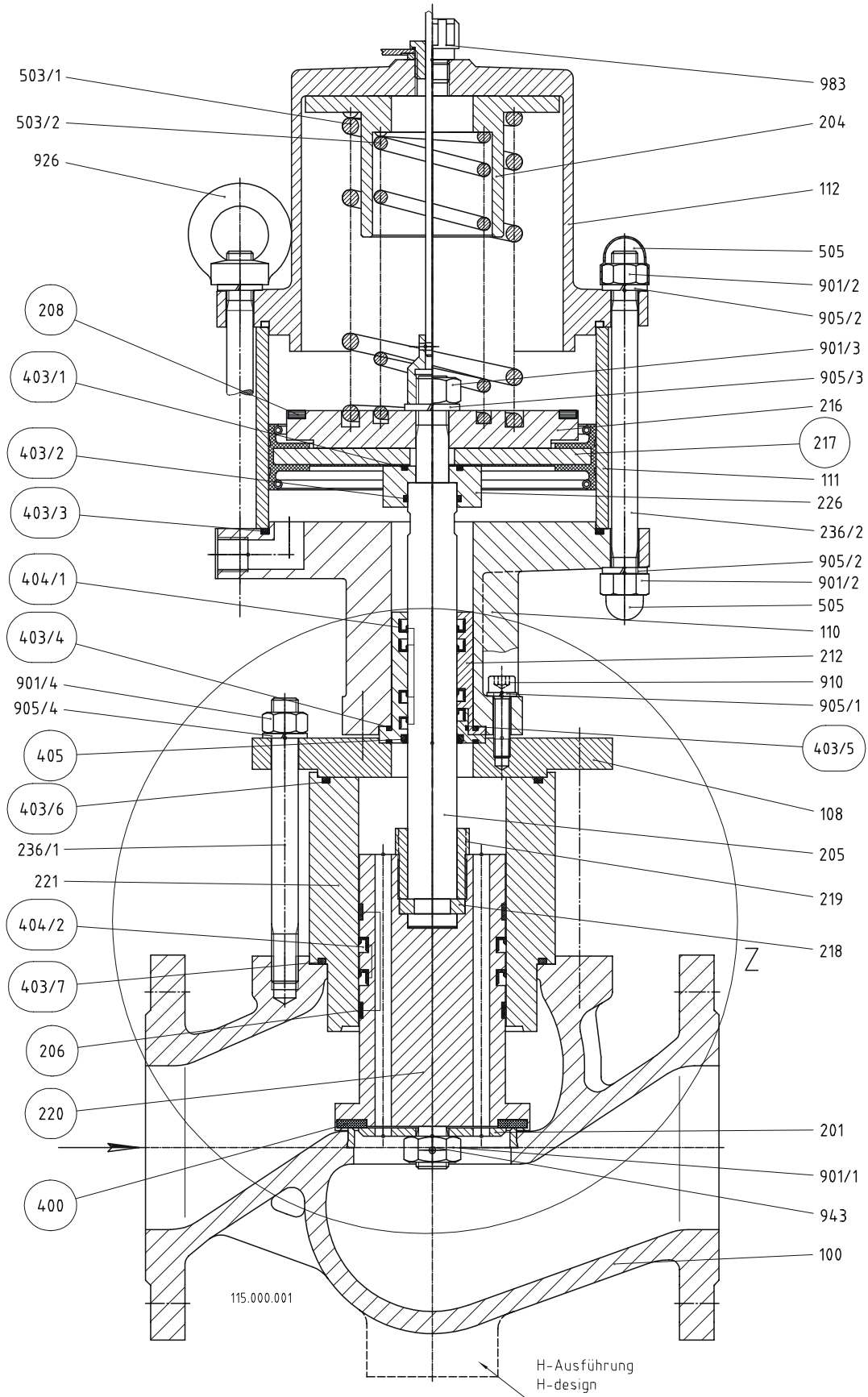

O = Wearing parts

Fig.3 detail 40-4 EPVA DN40/50/65

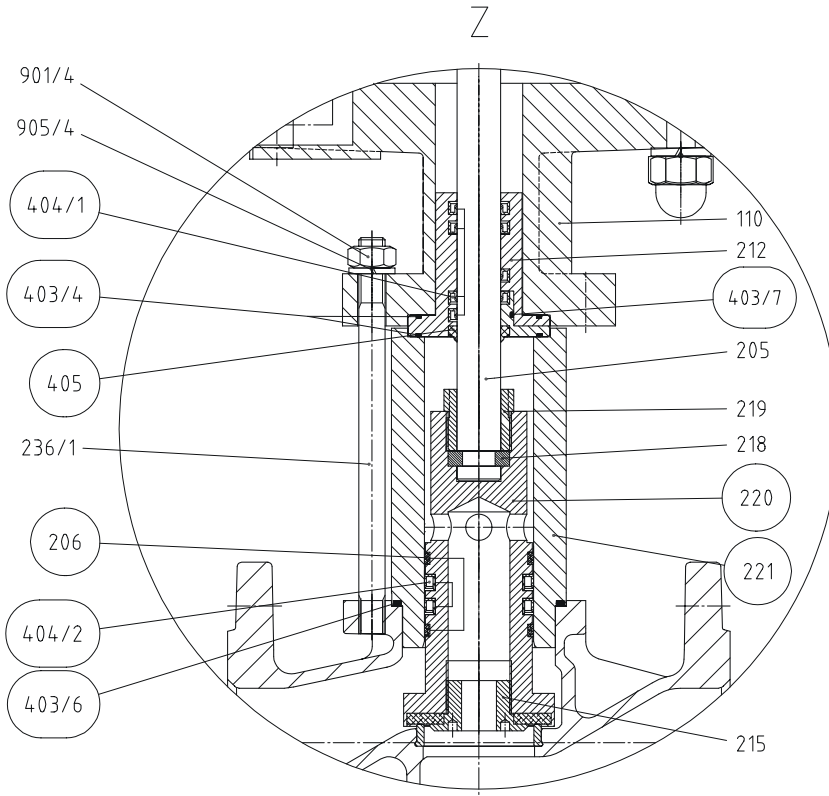

11.2 Fig.1 Projection
10-4 EPVA

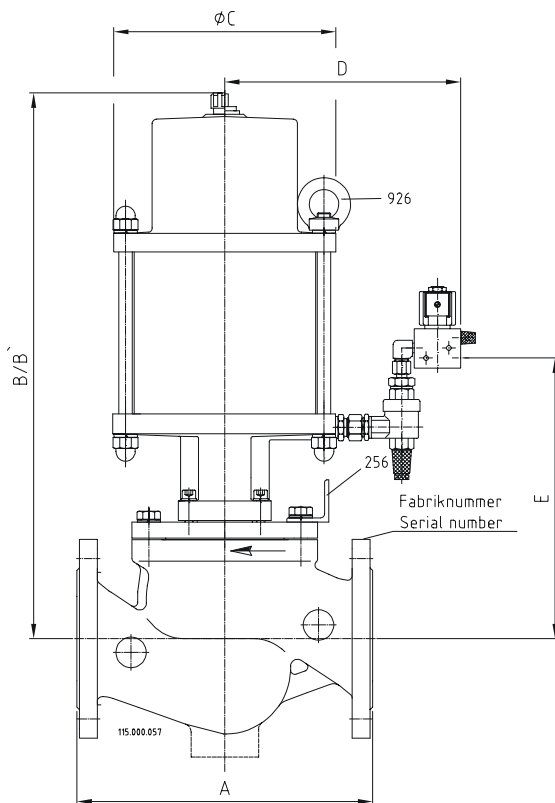

11.2 Fig.2 Projection
40-4 EPVA

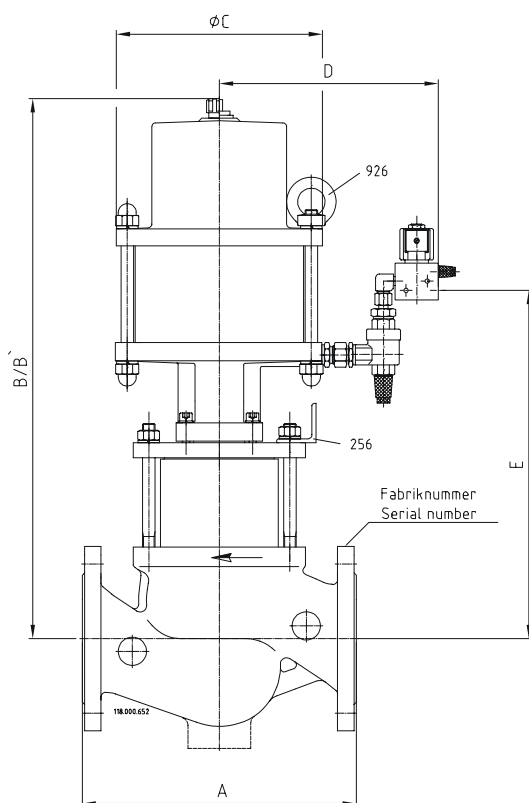

B' = Dimension for disassembling of complete drive

11.3 Control valve

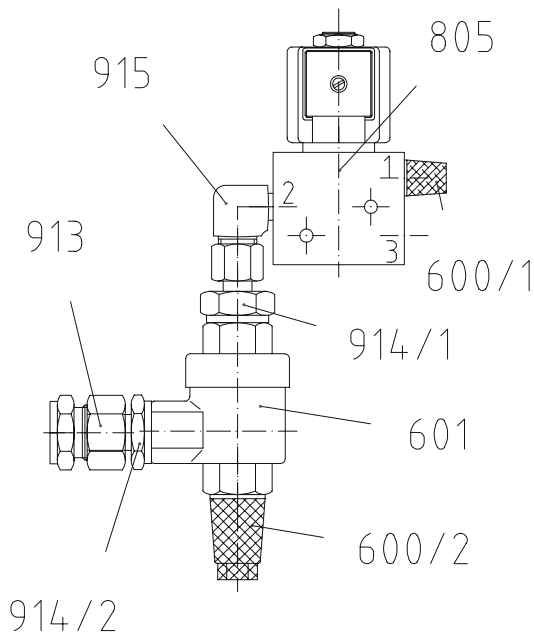

Connection 1 = Ventilation
Connection 2 = Drive
Connection 3 = Control air

11.4 List of parts

Pos./ Item	Stück/ Qty.	Benennung	Description
100	1	Ventilgehäuse	Valve chamber/ housing
108	1	Gehäuseflansch	Housing flange
110	1	Distanzstück	Spacer
111	1	Pneumatikzylinder	Pneumatic cylinder
112	1	Federdom	Spring cap
201	1	Tellerscheibe	Disc plate
204	1	Federführung	Spring guide pin
205	1	Ventilspindel	Valve spindle
206	2	Führungsring	Guide ring
208	1	Schlagdämpfung	Sound insulation
212	1	Spindelführung	Spindle guide
215	1	Tellerschraube	Plate screw
216	1	Federteller	Spring disc
217	1	Antriebskolben	Drive piston
218	1	Zweiteiliger Ring	Two-piece ring
219	1	Spindelmutter	Spindle nut
220	1	Ausgleichskolben	Balance piston
221	1	Kolbenführung	Piston guide
226	1	Dichtstück	Sealing piece
236	4/8	Stiftschraube	Stud
241	1	Ventiltelleraufhängung	Valve disc mounting
256	1	Transportwinkel	Transport angle
400	1	Ventiltellerdichtung	Valve disc sealing
402	2	Flachdichtung	Flat gasket
403/1	1	O-Ring	O-ring
403/2	1	O-Ring	O-ring
403/3	1	O-Ring	O-ring
403/4	2	O-Ring	O-ring
403/5	1	O-Ring	O-ring
403/6	1	O-Ring	O-ring
404/1	4	Lippenring	Lip-ring
404/2	2	Lippenring	Lip-ring
405	1	Abstreifring	Scraper ring

Pos./ Item	Stück/ Qty.	Benennung	Description
503/1	1	Druckfeder	Pressure spring
503/2	1	Druckfeder	Pressure spring
505	7/8	Schutzkappe	Protective cap
600/1	1	Schalldämpfer	Sound absorber
600/2	1	Schalldämpfer	Sound absorber
601	1	Schnellentlüfter	Quick-venting mechanism
805	1	Steuerventil	Control valve
900	4	Sechskantschraube	Hex. head screw
901/1	1	Sechskantmutter	Hex. nut
901/2	8	Sechskantmutter	Hex. nut
901/3	1	Sechskantmutter	Hex. nut
901/4	4	Sechskantmutter	Hex. nut
905/1	4	Federring	Lock washer
905/2	8	Federring	Lock washer
905/3	1	Federring	Lock washer
905/4	4/8	Federring	Lock washer
905/5	4	Federring	Lock washer
906	1	Scheibe	Washer
910	4	Zylinderschraube	Cylinder head screw
913	1	Gerade- Einschraubverschraubung	Linear threaded screw connection
914/1	1	Gerader Aufsteckstutzen	Linear put on adapter
914/2	1	Gerader Aufsteckstutzen	Linear put on adapter
915	1	Winkel- Einschraubverschraubung	Angle threaded screw connection
926	1	Ringmutter	Ring nut
941	1	Gewindestift	Set screw
943	1	Spannstift	Spring dowel sleeve
983	1	Entlüftungsstopfen	Exhaust plug

Ersatzteile/ wearing parts

Pos./Item	Stück/ Qty.	Benennung	Description
206	2	Führungsring	Guide ring
208	1	Schlagdämpfung	Sound insulation
217	1	Antriebskolben	Drive piston
220	1	Ausgleichskolben komplett (201, 400, 901/1, 903)	Balance piston compl. (201, 400, 901/1, 903)
402	2	Flachdichtung	Flat gasket
403/1	1	O-Ring	O-ring
403/2	1	O-Ring	O-ring
403/3	1	O-Ring	O-ring
403/4	2	O-Ring	O-ring
403/5	1	O-Ring	O-ring
403/6	1	O-Ring	O-ring
404/1	4	Lippenring	Lip-ring
404/2	2	Lippenring	Lip-ring
405	1	Abstreifring	Scraper ring

Dimension

Flange DN	Dimension	40	50	65	80	100	150	200	250	300
Installation length	A	200	230	290	310	350	480	600	730	850
	B	-	-	-	-	-	590	710	765	845
10-4 EPVA	B'	-	-	-	-	-	770	940	1040	1180
	ØC	-	-	-	-	-	170	210	210	265
	D	-	-	-	-	-	230	250	250	290
	E	-	-	-	-	-	360	435	480	545

Flange DN	Dimension	40	50	65	80	100	150	200	250	300
40-4 EPVA	B	460	570	590	560	670	-	-	-	-
	B'	550	670	690	670	800	-	-	-	-
	ØC	170	210	210	210	265	-	-	-	-
	D	230	250	250	250	290	-	-	-	-
	E	310	375	395	365	455	-	-	-	-

12.0 Declaration of Conformity

UNI-Geräte E. Mangelmann
Elektrotechnische Fabrik GmbH
Postfach 1261
D – 47649 Weeze



Konformitätserklärung Declaration of Conformity

Produkt
Product

Sicherheitsabsperrenteil
Safety shut-off valve

Handelsbezeichnung
Trade Mark

Pneumatikventil
Pneumatic Valve

Baureihe
Series

10-4-EPVA...-4.02

Nennweiten
Sizes

DN 150, DN 200, DN 250, DN 300

EU-Richtlinien
EC-Directives

90/396/EWG Gasgeräte-Richtlinie Gas Appliance Directive
98/37/EG Maschinenrichtlinie Machinery Directive
97/23/EG Druckgeräte-Richtlinie Pressure Equipment Directive
73/23/EWG Niederspannungsrichtlinie Low-Voltage Directive
89/336/EWG EMV-Richtlinie EMC Directive

Angewandte technische Spezifikation
Applied Technical Specification

DIN 3394-1
AD 2000

EG-Baumusterprüfung
EC-Type Examination

90/396/EWG
Deutsche Vereinigung des Gas- und Wasserfaches e.V. (DVGW)
Notified Body 0085

Überwachungsverfahren
Surveillance Procedure

90/396/EWG
Deutsche Vereinigung des Gas- und Wasserfaches e.V. (DVGW)
Notified Body 0085
97/23/EG
Bureau Veritas S.A., Paris
Notified Body 0062

Kennzeichnung
Marking

90/396/EWG CE-0085AQ0514
98/37/EG CE
97/23/EG CE 0062

Das Unternehmen UNI Geräte E. Mangelmann Elektrotechnische Fabrik GmbH bescheinigt hiermit, dass die o.a. Baureihe die grundsätzlichen Anforderungen der aufgeführten Richtlinien und Normen erfüllt.

UNI Geräte E. Mangelmann Elektrotechnische Fabrik GmbH confirms that the basic requirements of the above specified directives and standards are fulfilled.

Weeze, den 24.03.2003



Geschäftsführer
Managing Director



Leiter Konstruktion
Head of Design

UNI-Geräte E. Mangelmann
Elektrotechnische Fabrik GmbH
Postfach 1261
D – 47649 Weeze



Konformitätserklärung Declaration of Conformity

Produkt
Product

Sicherheitsabsperrventil
Safety shut-off valve

Handelsbezeichnung
Trade Mark

Pneumatikventil
Pneumatic Valve

Baureihe
Series

40-4 EPVA...

Nennweiten
Sizes

DN 40 – DN 100

EU-Richtlinien
EC-Directives

90/396/EWG Gasgeräte richtlinie *Gas Appliance Directive*
98/37/EG Maschinenrichtlinie *Machinery Directive*
97/23/EG Druckgeräte richtlinie *Pressure Equipment Directive*

**Angewandte
technische Spezifikation**
Applied Technical Specification

DIN 3394-1
AD 2000

EG-Baumusterprüfung
EC-Type Examination

90/396/EWG
Deutsche Vereinigung des Gas- und Wasserfaches e.V. (DVGW)
Notified Body 0085

Überwachungsverfahren
Surveillance Procedure

90/396/EWG
Deutsche Vereinigung des Gas- und Wasserfaches e.V. (DVGW)
Notified Body 0085
97/23/EG
Bureau Veritas S.A., Paris
Notified Body 0062

Kennzeichnung
Marking

90/396/EWG
98/37/EG
97/23/EG

CE-0085AQ0725
CE
CE 0062

Das Unternehmen UNI Geräte E. Mangelmann Elektrotechnische Fabrik GmbH bescheinigt hiermit, dass die o.a. Baureihe die grundsätzlichen Anforderungen der aufgeführten Richtlinien und Normen erfüllt.

UNI Geräte E. Mangelmann Elektrotechnische Fabrik GmbH confirms that the basic requirements of the above specified directives and standards are fulfilled.

Weeze, den 24.03.2003



Geschäftsführer
Managing Director



Leiter Konstruktion
Head of Design