

Operating and mounting manual

Safety shut off valve

EVS..Ü

Contents

1.0 General remarks

- 1.1 Valve data
- 1.2 Application

2.0 Danger Notices

- 2.1 Safety terms
- 2.2 Safety notice
- 2.3 Qualified staff
- 2.4 Unauthorized modification and spare part production
- 2.5 Unauthorized operation
- 2.6 Safety information for the use in explosion-prone areas guideline 94/9/EC

3.0 Handling

- 3.1 Transport
- 3.2 Storage
- 3.3 Handling before mounting

4.0 Product Description

- 4.1 Function
- 4.2 Technical Data
- 4.3 Marking

5.0 Installation

- 5.1 Warning of Dangers during Installation, Operation and Maintenance
- 5.2 Installation

6.0 Operation

- 6.1 Commissioning
- 6.2 Shutting down
- 6.3 Maintenance
- 6.4 Putting back into Operating

7.0 Troubleshooting

- 7.1 Detection of defects
- 7.2 Troubleshooting Plan

8.0 Dismantling of the Valve

- 8.1 Replacement of Wear Parts

9.0 Warranty

10.0 Explanations on Codes and Directives

11.0 Sectional Drawing

- 11.1 Flange design / thread design
- 11.2 List of parts

12.0 Declaration of Conformity

1.0 General remarks

This operating manual includes instructions to assemble and operate the valve in the prescribed and safe way. **Additionally, the adequate operation instructions (BTA) of each special solenoid drive must be considered.**

Series MG...	220.100.038
Series MG...X	220.100.040
Series MG...Xme	220.100.039

If any difficulties appear that can not be solved by means of the operating manual, further information may be demanded from the manufacturer.

This operating manual is in accordance with the relevant valid EN safety standards and the valid prescriptions and rules of the Federal Republic of Germany.

If the solenoids are used abroad of the FRG, the operator and/or the person who is responsible for the plant concept must take care that the valid national rules are met.

The manufacturer reserves the right of any technical change and improvement.

The use of these operating instructions suppose the qualification of the user according to paragraph 2.3 "qualified staff".

The operating staff must be trained in accordance with the operating instructions. The operating manual must always be available at the location where used.

1.1 Valve Data

Manufacturer:

UNI Geräte E. Mangelmann
Elektrotechnische Fabrik GmbH
Holtumsweg 13
D-47652 Weeze
Telefon: +49 (0) 2837/9134-0
Fax: +49 (0) 2837/1444
E-Mail: info@uni-geraete.de
Homepage: www.uni-geraete.de

Designation

Directly functioning, currentless closed, spring safety shut off valve with solenoid drive.

Type test acc. to DIN EN 264

Working pressure:

4-EVS..Ü	0 - 4bar
10-EVS..Ü	0 - 10bar
40-EVS..Ü	0 - 40bar

Medium temperature: -10°C to + 140°C

Ambient temperature: -10°C to + 60°C

Fitting position: vertical or horizontal drive

Switching cycles: 1000 cycles/h for solenoid drives with one winding,
20 cycles/h for solenoid drives with pickup and holding winding
MG...A₁/ A₂/ A₃ see section 4.2.
600 cycles/h for MG...A5

Threaded connection dimension at DIN ISO 228-1

Connection G	TÜV-Report-no.:	1/4	3/8	1/2	3/4	1	1 1/4	1 1/2	2	Design pressure PS = PN
4-EVS...-4Ü	S 89/97	X	-	-	-	-	-	-	-	PN 10
	S 90/97	-	X	X	X	-	-	-	-	PN 10
	S 91/97	-	-	-	-	X	-	-	-	PN 10

Connection G	TÜV-Report-no.:	1/4	3/8	1/2	3/4	1	1 1/4	1 1/2	2	Design pressure PS = PN
4-EVS...-4Ü	S 92/97	-	-	-	-	-	X	-	-	PN 10
	S93/97	-	-	-	-	-	-	X	-	PN 10
	S94/97	-	-	-	-	-	-	-	X	PN 10
10 EVS 24Ü*	S 19/00	X	-	-	-	-	-	-	-	PN 16
10 EVS 5Ü	S 21/00	-	-	X	-	-	-	-	-	PN 16
40 EVS 5Ü	S 20/00	-	-	X	-	-	-	-	-	PN 40

* passage 4mm

X Acceptance test certificate 3.2, O Acceptance test certificate 3.2 possible, - not available,

Flange connection measures acc. to DIN EN 1092-2 / ANSI

Flange DN	TÜV-Report-no.:	15	20	25	32	40	50	65	80	100	125	150	Design pressure PS = PN
Flange ANSI		1/4"	3/8"	1/2"	11/4"	11/2"	2"	21/2"	3"	4"	-	6"	
4-EVS..NHÜ..	S 90/97	X	X	-	-	-	-	-	-	-	-	-	PN 10
	S 91/97	-	-	X	-	-	-	-	-	-	-	-	PN 10
	S 92/97	-	-	-	X	-	-	-	-	-	-	-	PN 10
	S 93/97	-	-	-	-	X	-	-	-	-	-	-	PN 10
	S 94/97	-	-	-	-	-	X	-	-	-	-	-	PN 10
	S 95/97	-	-	-	-	-	-	X	-	-	-	-	PN 10
	S 96/97	-	-	-	-	-	-	-	X	X	-	-	PN 10
	S 4/99	-	-	-	-	-	-	-	-	-	X	-	PN 10
	S 5/99	-	-	-	-	-	-	-	-	-	-	X	PN 10
10 EVS..NHÜ..	S 114/01	X	X	X	-	-	-	-	-	-	-	-	PN 16
	S 9/00	-	-	-	X	-	-	-	-	-	-	-	PN 16
	S 10/00	-	-	-	-	X	-	-	-	-	-	-	PN 16
	S 115/01	-	-	-	-	-	X	-	-	-	-	-	PN 16
	S 11/00	-	-	-	-	-	-	X	-	-	-	-	PN 16
	S 12/00	-	-	-	-	-	-	-	X	-	-	-	PN 16
	S 13/00	-	-	-	-	-	-	-	-	X	-	-	PN 16
	S14/00	-	-	-	-	-	-	-	-	-	X	-	PN 16
	S 15/00	-	-	-	-	-	-	-	-	-	-	X	PN 16

X Acceptance test certificate 3.2, O Acceptance test certificate 3.2 possible, - not available,

Voltage: 24V– 420V (–15% bis +10%)
Protection type: IP54 or IP65
Frequency 40 – 60 Hz
Power 10 – 4000W

Details to the electrical data can be found on the type sign and the adequate operation instruction of the solenoid valves.

1.2 Application

The UNI Geräte Solenoid valves EVS..Ü are used as automatic safety shut-off valves for qualified to secure, limitation, shut-off and release the fuel oil supply in steam generators and thermal process systems.

The valves are qualified for fuel oil EL and M according to DIN 51603 and other liquids having a viscosity rates up to 75mm². Not suitable for heavy fuel S.

If used in other cases, the operator must carefully check if construction/design of valve, accessories and materials are suitable for the new application. The range of application is subject to the responsibility of the plant planner. The service life of the valve is 20 years.

2.0 Danger Notices

2.1 Safety Terms

The signal terms DANGER, CAUTION und NOTICE are used in this operating manual in case of notices concerning special dangers, or for unusual information, requiring a special marking.



DANGER! means that in case of non-observance there is danger to life and/or considerable damage.



CAUTION! means that in case of non-observance there is danger of injury and/or damage.



NOTICE! means that attention is drawn to technical correlations/connections.

Observance of other, not especially marked notices concerning transport, assembly, operation and maintenance and other data (in the operating manual, product documentation and at the unit itself) is also essential, in order to avoid disturbances that might affect direct or indirect damage to property or injury to persons.

2.2 Safety Notice

Non observance of safety instructions can lead to loss of any claim for damages.

Non observance can lead to the following mentioned dangers:

- Failure of important functions of the valve/plant
- Endangering of persons by electrical or mechanical influences.
- Protection against accidental contact for moving parts may not be removed as long as the valve is in operation.
- Leakage of dangerous media (e.g. explosive, toxic, hot) must be removed in the way that there is no danger for persons or environment. Laws and regulations must be observed.

2.3 Qualified staff

These are persons who are familiar with erection, assembly, starting, operation and maintenance of the product and who have special qualifications acc. to their activities and functions, e.g.:

- Instruction and obligation to carry out and meet all regional and in-house orders and requirements.
- Education or instruction according to the safety engineering standards in use and maintenance of adequate safety and working protection equipment.
- Training in first aid.

2.4 Unauthorized Modification and Spare Part Production

Modification or changes of the valve are only allowed after agreement of the manufacturer. Original drawings and accessories authorized by the manufacturer are for safety purposes. The use of other parts or unauthorized constructive changes at the valve by third persons may cancel and abolish the manufacturer's liability for resulting consequences.

2.5 Unauthorized Operation

Operational reliability of the delivered valve is only guaranteed in case of determined use in accordance to paragraph 1 of the operating manual. **The application limits mentioned on the type sign may on no account be exceeded.**

2.6 Safety information for the use in explosion-prone areas guideline 94/9/EC

- The temperature of the medium must not exceed the respective temperature class, and respectively, the respective maximum permitted medium temperature as per operation guideline.

- If the valve is heated (e.g. heating jacket), care must be taken, that the specified temperature class is kept in the time.
- The valve must be connected to the ground.
In the case most simple this can be realized via pipe screws by means of tooth disc.
Otherwise the connection to the ground must be implemented by other measures e.g. cable links.
- Control valves, electrical and electrical/mechanical drives as well as sensors must undergo a separate conformity check as per ATEX. In doing so the respective safety and explosion protection information in the operation instructions are to taken into special consideration.

Furthermore we point out the guideline 95/C332/06(ATEX 118a), which include the minimum regulations for the improvement of the health-related situation and the safety of the employees, who might be jeopardized by an explosive atmosphere.

3.0 Handling

3.1 Transport

For any transport works, the generally recognised technical rules and standards as well as rules for prevention of accidents must be observed.

In case of transport, storage and stopping, the flange protection caps must be mounted at both valve flanges.

The goods to be transported must be carefully treated. During transport, the valve must be protected against strokes, impacts or vibration. The coat of lacquer may not be damaged. Transport temperature is -20°C up to $+60^{\circ}\text{C}$.

Never transport the valve at screwed cable glands, appliance plugs or add-on units. The valve can be transported at ring nuts, flange borings or by means of a belt under the solenoid drive.

Transport the valve in a case or on a pallet with smooth base and put it softly on plain floor. **Never put the valve on limit switch box.**

The goods must be checked on completeness and transport damage. See also section 9.0

3.2 Storage

If the valve is not installed immediately after delivery, it must be stored properly.

- Storage temperature -20°C up to $+60^{\circ}\text{C}$, dry and clean.
- The lacquer protects against corrosion in neutral dry atmosphere. Do not damage colour.
- In humid rooms, a drying agent or a heating resp. is necessary because of condensation of water.

Requirements according to DIN 7716 (products made of caoutchouc and rubber) must be met.

3.3 Handling before Mounting

- In case of valve with protection caps, they must be removed before being mounted!
- Protect against atmospheric influences such as humidity (otherwise use drying agent).
- Appropriate treatment protects against damage.

4.0 Product description

The UNI-Geräte oil – solenoid valve EVS..Ü is a directly controlled, currentless closed safety shut-off valve acc. to DIN EN 264 with solenoid drive.

Sectional drawing 11.1 Fig. 1 to Fig. 4 shows the valve construction.

4.1 Function

By switching on the solenoid drive (800), the solenoid core (207) is drawn against the upper part (106). The pressure spring (503) is pressed and the balance piston (220) releases the valve cross section. The valve is open.

The valve closes by switching off, interruption or failure of power energy to solenoid drive (800). Due to press of the pressure spring (503) the balance piston (220) closes. The valve is closed at 15% of nominal voltage.

4.2 Technical Data

Opening times: 0,3 – 0,7s
Closing times: < 1s

Solenoid –drive types MG...

Connection G	1/4	3/8	1/2	3/4	1	1 1/4	1 1/2	2
4-EVS..Ü	005-3	008-2	008-2	008-2	010	012	014	016
10-EVS..Ü	3803	-	008-2	-	-	-	-	-
40-EVS..Ü	-	-	012	-	-	-	-	-

Flange DN	15	20	25	32	40	50	65	80	100	125	150
Flange ANSI	1/2"	3/4"	1"	1 1/4"	1 1/2"	2"	2 1/2"	3"	4"	-	6"
4-EVS..Ü	008-2	008-2	010	012	014	016	018	019A5	018A1	018A1	019A2
10-EVS..Ü	010	010	010	012A5	014A5	016A5	019A5	018A1	018A1	019A1	019A2

Drive types with "A" consist of pickup and holding winding

Starting torque, pipe screws greased

DN	8	10	15	20	25	32	40	50	65	80	100	125	150
Torque Nm	20	30	30	30	30	50	50	50	50	50	80	160	160

Starting torque, product screws and nuts greased

Screw	M6	M8	M10	M12	M16	M20	M24
Torque Nm	5	11	22	39	70	110	150

4.3 Marking

The type sign on the solenoid drive has the following information:

- Fabricator
- Valve type, nominal width, pressure and temperature indication, fitting position
- Year of construction/ production no.
- TÜV-report No.
- Valve class
- CE-sign
- Relevant location Fluid group and test pressure PT
- Solenoid drive type
- Electr. performance
- Voltage
- Frequency
- Protection type

to DIN EN 264

CE

to 97/23/EC (PED)

When using solenoid drives for x-protection zone 1 refer to information in the valid operation instruction.

Refer also to section 10.0.

5.0 Installation

5.1 Warning of Dangers during Installation, Operation and Maintenance



DANGER!

Safe operation of the valve can only be guaranteed if it is installed, commissioned and maintained by qualified personnel (see point 2.3 “Qualified staff”) correctly and in observance of the warnings in this operating manual. Apart from that, the operation safety order and the qualified use of tools and protection equipment must be guaranteed. The operating instructions for the valve must be observed during all work on or with the valve. Failure to observe these instructions may result in injury or in damage to the valve or other installations.

In case of use of the valve as sealing end, we recommend safety measures like for example blanks, blind flanges, etc. in case of maintenance work.

5.2 Installation

Apart from the general installation guidelines, the following points should be observed:



NOTICE!

- Remove the flange covers.
- The inside of the valve and the pipeline must be free from foreign particles.
- Observe the installation position in relation to the flow direction, see markings on the valve.
- Centre gaskets between the flanges.
- The connecting flanges must be aligned.
- Ensure that none of the components is strained during installation.
- The valve must not be used as a fixed point; it is supported by the pipework system.
- Protect valves from soiling, particularly during construction work.
- Thermal expansion of the pipework must be equalized using compensators.

According to DIN EN 264 a dirt catcher must be installed in front of every safety lock valve. The mesh diameter inside of the sieve must be 0.5 mm. In case of two safety lock valves combined it is sufficient to install one dirt catcher in front of the first valve. The dirt catcher must be installed in a not too far distance from the first valve. The UNI-Geräte dirt catcher of the SF series are permitted for the use of flange valve.

The valve can be installed with vertical or horizontal, but not suspended solenoid drive.



NOTICE!

Please observe the solenoid drive operating instructions (BTA).

6.0 Operation



DANGER!

Before commissioning a new installation or before starting up an installation again after repairs or modifications, ensure:

- The proper completion of all installation and assembly work!
- Commissioning only by “qualified staff” (see point 2.3).
- Installation or repair of existing guards and protection equipment.

6.1 Commissioning

- Before commissioning, check the data on material, pressure, temperature and flow direction with the layout plan of the pipework system.
- Depending on the field of application, the local regulations have to be observed, e.g. the operation safety order.
- Residues in the pipework and the valve (dirt, weld beads, etc.) will inevitably result in leaks.
- Leakage inspection of the installed valve.

6.2 Shutting Down

- Depending on the field of application, the local regulations have to be observed, e.g. the operation safety order.

6.3 Maintenance

Oil – solenoid valves must be checked for their function and internal leakage within regular periods of time. The operator must respectively determine the intervals for regular checks according to the operating instructions. UNI-Geräte recommends a visual control of the inside once a year and an overhauling of the valve after two years.

6.4 Putting Back into Operation

When putting a valve back into operation, ensure that all the necessary steps described in section 5.2 (Installation) and section 6.1 (Commissioning) are repeated.

7.0 Troubleshooting

7.1 Detection of defects



DANGER!

Be sure to observe the safety instructions during troubleshooting.

If the malfunctions cannot be remedied using the following **“Troubleshooting plan (7.2)”** please contact the manufacturer.

In the event of faults in the function or operating behaviour of the valve, check whether the installation work was carried out and completed as described in this operating manual. Depending on the field of application, the operation safety order must be observed.

Check the data on material, pressure, temperature, voltage and flow direction with the layout plan of the pipework system. In addition, check whether the operating conditions correspond to the technical data in the data sheet or on the rating plate.

7.2 Troubleshooting Plan

Malfunction	Possible causes	Remedy
No flow	Valve does not open	Switch on solenoid drive (800) Check operating voltage
	Working pressure too high	Compare working pressure with the data on the rating plate
	Flange covers were not removed	Remove flange covers
Low flow rate	Contaminated strainer	Filter clean/exchange
	Clogging in the pipework system	Check pipework system
Valve leaking at seat, no internal tightness	Valve seat gasket (400) or valve seat (100) damaged by external particles	See section 8 or replace valve
No external tightness	Gaskets damaged	See section 8 or replace valve
Valve does not close	Connected voltage too high	Check whether there is residual voltage, see section 4.1
Flange fracture (valve/pipework)	Screws not tightened uniformly, mating flanges not aligned	Align pipework. Install new valve



NOTICE!

Observe section 10.0 before all installation and repair work!

Observe section 6.4 when putting the valve back into operation!

8.0 Dismantling of the Valve

In addition to the general installation guidelines and the operation safety order, the following points must also be observed:



DANGER!

- Depressurised pipework system
- Cooled medium
- Emptied installation
- Vent pipework systems containing corrosive, inflammable, aggressive or toxic media
- Have dismantling work carried out only by qualified staff (see point 2.3)

8.1 Replacement of Wear Parts

Shut down the valve as described in section 6.2.

Switch off and dismantle the solenoid drive as described in the operating manual of the solenoid drive.



DANGER!

After continuous operation, the solenoid drive may be hot! Danger of burns!

Flanged version

Fig. 1 4/10 EVS..Ü

Loosen hex. bolts (900/1) and remove housing flange (108). Remove upper part of housing assembly (106). Remove bolt (902/1) together with SL retainer (949) or split pin (912) and place solenoid core (207) together with spring bolt (210/1) and pressure spring (503/1) aside on a clean surface. Then remove balance piston (220/1) together with piston guide (221/1) from valve chamber (100) and separate the balance piston from the piston guide.

Threaded version

Fig. 2 4 EVS..Ü

Unscrew upper part of housing assembly (106) from piston guide (221/1). Remove bolt (902/1) together with SL retainer (949) or split pin (912) and place solenoid core (207) together with spring bolt (210/1), pressure spring (503/1) and filter sieve (965) aside on a clean surface. Then unscrew balance piston (220/1) together with piston guide (221/1) from valve chamber (100) and separate the balance piston from the piston guide.

Fig. 3 10 EVS 24Ü

Unscrew upper part of housing assembly (106) from valve chamber (100). Remove solenoid core (207) together with pressure spring (503/1) and filter sieve (965) from valve chamber (100) aside on a clean surface.

Fig. 4 10/40 EVS 5Ü

Unscrew upper part of housing assembly (106) from piston guide (221). Remove pressure spring (503/2) with spring bolt (210) out of valve chamber (100). Remove piston guide (221) from valve chamber (100). Loosen set screw (941) and remove solenoid core (207) from valve disk (200) aside on a clean surface. Then remove filter sieve (965) from valve chamber (100).

During the visual inspection, pay attention to the following points:

1. Damage to the valve seat (100).
2. Damage to the valve disc seal (400)
3. Soiling or foreign particles in the valve chamber (100)

4. Scores on the balance piston (220)
5. Scores in the piston guide (221)
6. Wear of the guide rings (206)

In the event of damage to the valve seat replace valve chamber (100), and in the event of damage to the valve seat gasket (400) replace balance piston (220). Remove soiling or foreign particles in the valve chamber (100). Replace worn guide rings (206). Individual parts showing signs of wear must be replaced.



NOTICE!

Before assembly, replace O-rings (403/1/2) and lip-ring (404/1/3). Lubricate the piston guide (221/1) with Staburags N32 lubricant.



DANGER!

For special application such as for oxygen use only the approved Lubricants.

Assemble the valve in the reverse order to the dismantling.



CAUTION!

Install wear parts carefully and properly and do not damage them during assembly.

Examine the valve for internal and external leaks in accordance with DIN EN 264 and finally carry out a function test.

9.0 Warranty

Scope and period of the warranty is specified in the edition of the "General Terms of Business of the UNI-Geräte E. Mangelmann Elektrotechnische Fabrik GmbH" valid at the time of delivery or else in the purchase agreement.

We warranty that the valve is free from faults in line with the state of the art and for the confirmed field of application.

No warranty claims will be accepted for damage resulting from improper use or failure to observe these operating and installation instructions, the statutory accident prevention regulations, the EN, DIN and VDE standards and other codes and regulations.

Warranty claims will also not be accepted for damage occurring during operation due to operating conditions deviating from those specified in the data sheet or in other agreements.

Justified complaints will be remedied by reworking by us or specialist companies authorised by us.

Claims going beyond the scope of the warranty will not be accepted. The customer shall have no right to the supply of a replacement valve.

Maintenance work, installation of parts from other manufacturers, any modifications to the design and natural wear are not covered by the warranty.

Transport damage must be reported not to us but **without delay** to your responsible goods handling company, the railway company or the shipping agent as otherwise all claims for damages against these companies will be voided.

10.0 Explanations on Codes and Directives

The Council of the European Community has passed common guidelines for the free exchange of goods within the Community; these guidelines determines a minimum of requirements for safety and protection of health. The type test confirms that products correspond to the EC guidelines, i.e. are in conformity with the relevant, especially harmonized standards. The directives DIN EN 264 refer to oil solenoid valve (mechanical part).

Notes concerning directives DIN EN 264:

The valves must be developed, manufactured and checked under observation of standard DIN EN 264. This is proven by the type test.

Notes concerning directives 2006/42/EG (machine directives):

The valves were developed, manufactured and checked under observation of directive 98/37/EG.

Notes concerning directives 97/23/EG (directive for pressure appliances, DGRL):

It was confirmed that the manufacturer UNI-Geräte E. Mangelmann Elektrotechnische Fabrik GmbH fulfils quality assurance with regard to design control, manufacturing and final inspection as per the requirements of 98/23/EG annex III module H. The oil solenoid valves correspond to the basic requirements of guidelines 97/23/EG. Valves with permitted operating pressures of $\leq 0,5\text{bar}$ and $\text{DN} \leq 25$ do not all under 97/23/EG. The marks as per 97/23/EG must only be implied in case of products, which fall under DGRL and are in Kat I or higher. Fluid group 1 includes explosion-prone, inflammable and poisonous matters. Die Fluid group 2 includes media, which are no included in fluid group 1.

The directives 73/23/EWG and 89/336/EWG refer to the solenoid drive (800).

Notes concerning directive 2006/95/EG (low voltage directive):

The drives were developed, designed and manufactures under observation of the standard "Solenoid appliances" DIN EDV 0580. Therefore the requirements of the low voltage directive are also fulfilled, which applies to low voltages of 50 to 1000V AC and 75 to 1500V DC.

Note on Directive 2004/108/EG (EMC Directive):

The magnet fulfil the requirements of the product family standards EN 55014-1,-2 , EN 61000-3-2, -3-3 for the industrial sector as well as for the sectors of housing, business and trade in small businesses.

When using AC and DC versions, the user must provide a suitable mains filter (e.g. X capacitor 47 nF) at the connection to the mains power supply in order to suppress the physical mains-borne turn-off interference of the solenoid coil.

Solenoid drives as drive elements for valves do not represent independently operated devices in the sense of the EMC Directive and are only further processed by specialist companies or are installed in a machine. Commissioning is not permitted until it has been determined that the whole machine or plant complies with the provisions of the EMC Directive.

For solenoid drives for explosion-proof zone 1, see the relevant operating manual for the solenoid drives.

Note concerning ex-guideline 94/9/EC (explosion guideline ATEX):

The product is not subject to guideline 94/9/EC, since due to the loads occurring during practical operation, there is no effective source of ignition even in case of an error case to be assumed. This also applies for spring-loaded components, like for example the pneumatic drive. In case of electric drives, sensors or other electric components the application as per 94/9/EC is to be checked separately.

National Codes and Directives

For the use of safety shut-off devices in accordance with DIN EN 12952-8 or DIN EN 746, the requirements of DIN EN 264 have to be satisfied. This is confirmed by a type test or by an acceptance test certificate to EN 10204-3.2.

Thread connection may be used as follows:

DIN EN 746-2			DIN EN 12952-8		TRD 411	
pressure bar	Nominal width	Comment	Nominal width	Comment	Nominal width	Comment
≤ 10	$\leq G 1$	Sealing material EN 751-1,-2 max. 150°C	$\leq G 1$	Cutting ring connection	$\leq G 1 / \text{DN } 25$	Metal seal
≤ 40	$\leq G 1 1/4$	Cutting ring connection	$\leq G 2$	Metal seal, non hardening sealing material	$\leq G 1 1/4 / \text{DN } 32$	Cutting ring connection

11.0 Sectional drawing

11.1 Fig.1 Flange design: 4/10-EVS..Ü

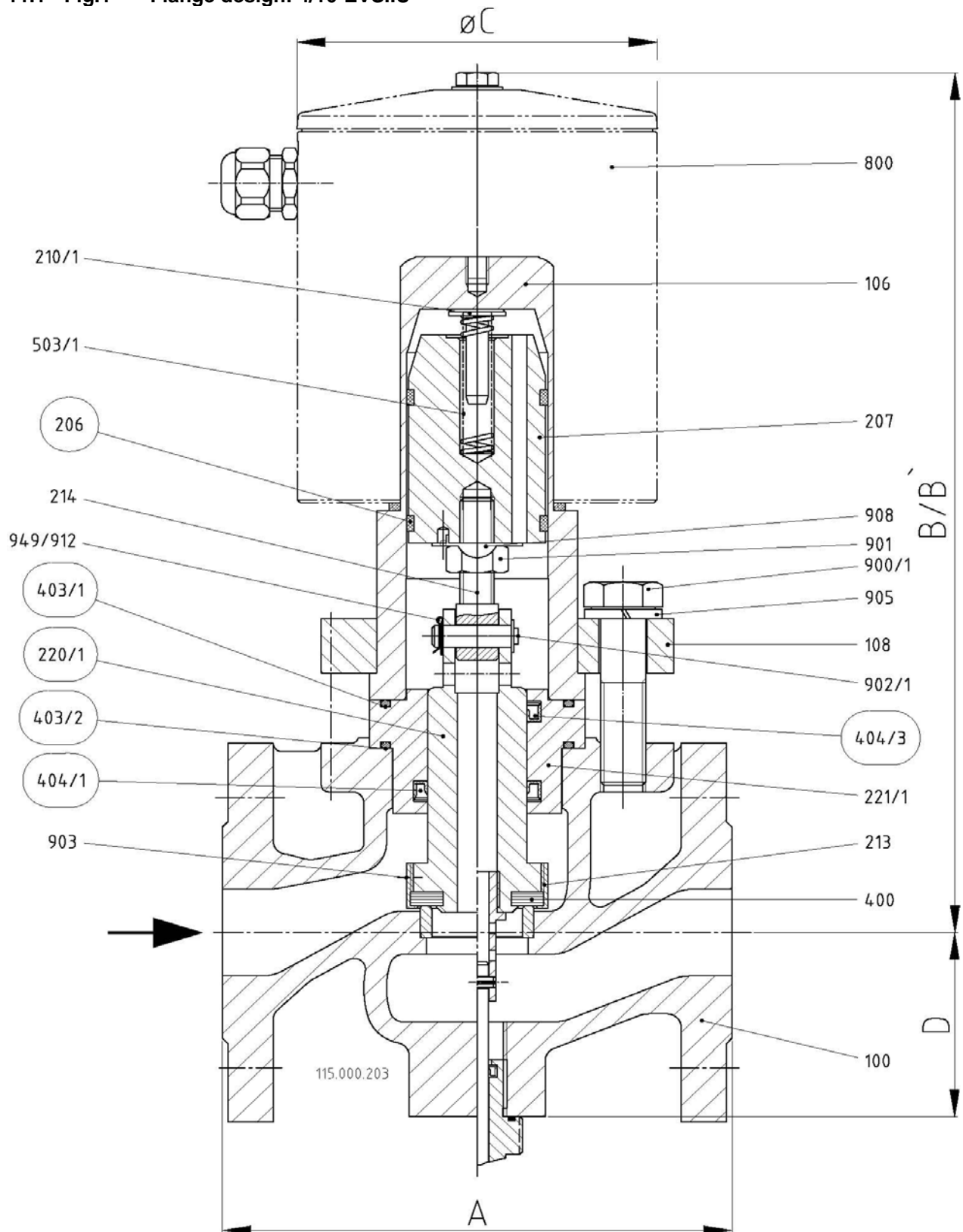

O = Wearing parts

B' = Dimension for removing the solenoid drive

Fig.2 Threaded version: 4-EVS..Ü
ØC

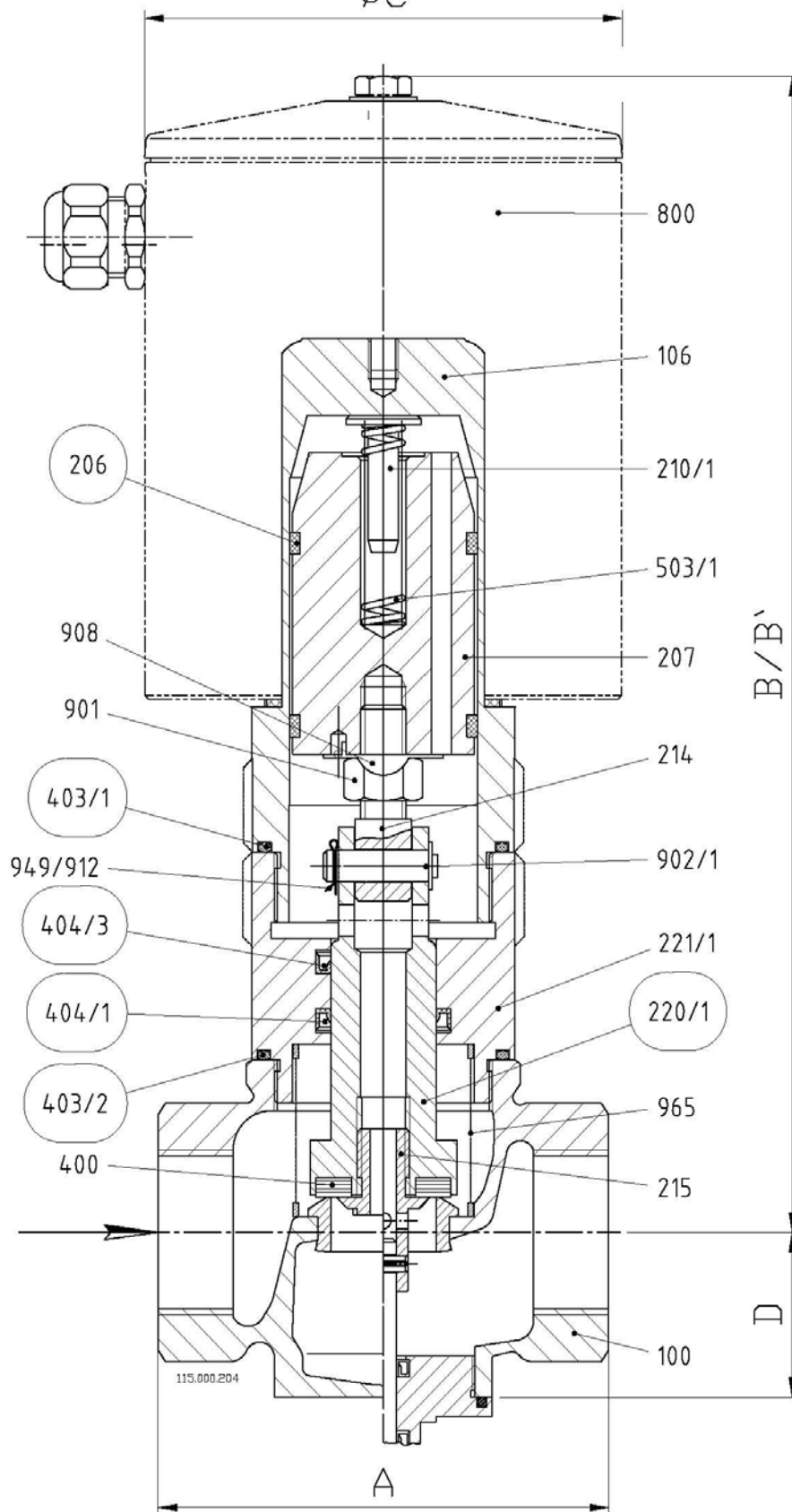

O = Wearing parts
B' = Dimension for removing the solenoid drive

Fig.3 Threaded version: 10-EVSA 24Ü

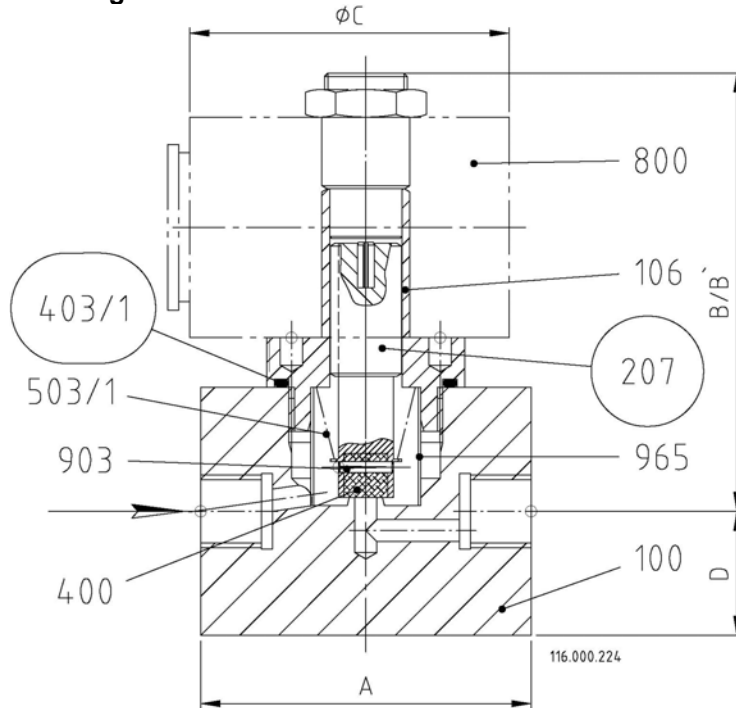
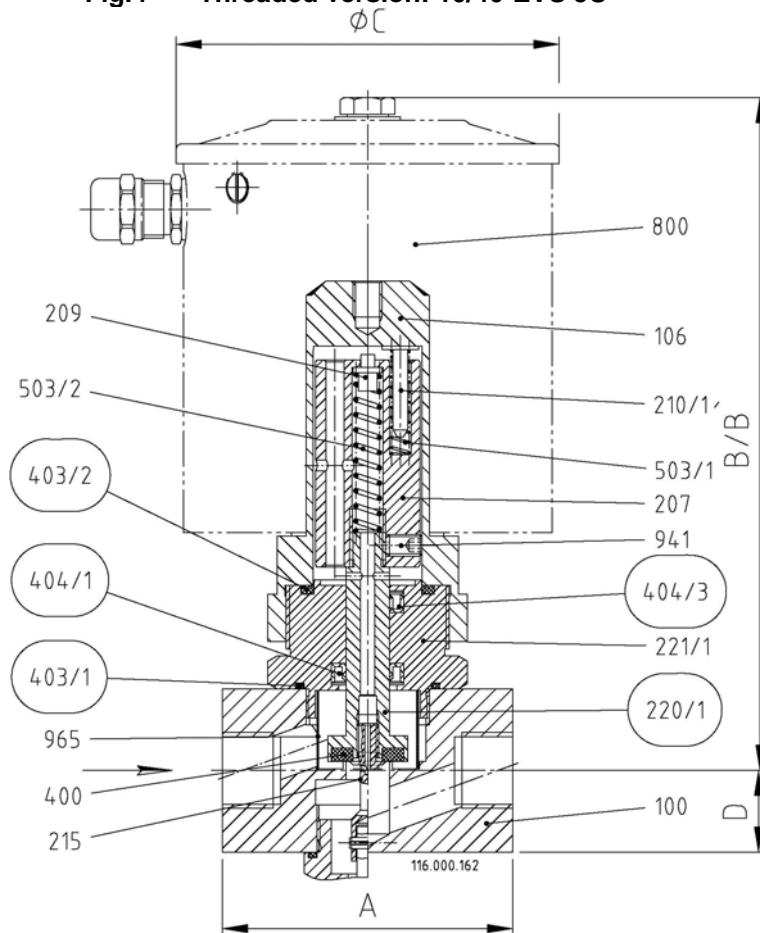

Fig.4 Threaded version: 10/40-EVS 5Ü



O = Wearing parts

B' = Dimension for removing the solenoid drive

11.2 List of parts

Pos./ Item	Stück/ Qty.	Benennung	Description
100	1	Ventilgehäuse	Valve chamber
106	1	Gehäuseoberteil	Upper part of housing
108	1	Gehäuseflansch	Housing flange
200	1	Ventilteller	Valve disk
206	2	Führungsring	Guide ring
207	1	Magnetskern	Solenoid core
209	1	Abwurfbolzen	Discharge bolt
210/1	1/3	Federbolzen	Spring bolt
213	1	Gewinding	Threaded ring
214	1	Ventilstift	Valve pin
215	1	Tellerschraube	Plate screw
220/1	1	Ausgleichskolben	Balance piston
221/1	1	Kolbenführung	Piston guide
400	1	Ventiltellerdichtung	Valve disk seal
403/1	1	O-Ring	O-ring
403/2	1	O-Ring	O-ring
404/1	1	Lippenring	Lip-ring
404/3	1	Lippenring (nur bei Gegendruck)	Lip-ring (only by back pressure)
503/1	1/3	Druckfeder	Pressure spring
503/2	1	Druckfeder	Pressure spring
800	1	Magnet-Antrieb	Solenoid drive
900/1	4/6/8/12	Sechskantschraube	Hex. head screw
901	1	Sechskantmutter	Hex. nut
902/1	1	Bolzen	Bolt
903	1	Kerbstift	grooved dowel pin
905	4/6/8/12	Federring	Lock washer
908	1	Sicherungsblech	Safety plate
912	1	Splint	Split pin
941	1	Gewindestift	Setscrew
949	1	SL-Sicherung	SL-retainer
965	1	Filtersieb	Filter sieve

Wearing parts

Pos./Item	Stück/ Qty.	Benennung	Description
206	2	Führungsring	Guide ring
207	1	Magnetskern kompl. (207; 400; 903)	Solenoid core compl. (207; 400; 903)
220/1	1	Ausgleichskolben kompl. (213, 215, 220/1, 400, 902/1, 903, 912, 949)	Balance piston compl. (213, 215, 220/1, 400, 902/1, 903, 912, 949)
403/1	1	O-Ring	O-ring
403/2	1	O-Ring	O-ring
404/1	1	Lippenring	Lip-ring
404/3	1	Lippenring (nur bei Gegendruck)	Lip-ring (only by back pressure)

Dimension with standard solenoid drive

Connection G	Dimension	1/4	3/8	1/2	3/4	1	1 1/4	1 1/2	2	
Installation length	A	60	80	80	95	105	120	150	170	
	4-EVS..Ü	B	190	220	220	220	260	290	345	380
		B'	250	300	300	300	350	380	465	500
		ØC	85	106	106	106	127	127	153	153
10-EVS ..Ü	D	22,5	22,5	22,5	21	30	40	50	50	
	B	100	-	176	-	-	-	-	-	
	B'	160	-	256	-	-	-	-	-	
	ØC	55	-	106	-	-	-	-	-	
	D	22,5	-	22,5	-	-	-	-	-	

Connection G	Dimension	1/4	3/8	1/2	3/4	1	1 1/4	1 1/2	2
Installation length	A	60	80	80	95	105	120	150	170
	B	-	-	202	-	-	-	-	-
40-EVS..Ü	B`	-	-	297	-	-	-	-	-
	ØC	-	-	127	-	-	-	-	-
	D	-	-	22,5	-	-	-	-	-

Dimension with standard solenoid drive

Flange DN	Dimension	15	20	25	32	40	50	65	80	100	125	150
Installation length	A ¹⁾	130	150	160	180	200	230	290	310	350	400	480
	A ²⁾	108	118	127	140	165	203	216	241	292	-	406
4-EVS..Ü	B	240	240	290	320	370	380	426	440	470	510	550
	B`	320	320	380	420	490	520	586	600	630	670	710
	ØC	106	106	127	127	153	153	191	191	191	191	191
	D	50	50	55	68	68	75	90	110	143	151	167
10-EVS..Ü	B	290	290	290	320	370	380	430	440	470	510	550
	B`	380	380	380	420	490	520	590	600	630	670	710
	ØC	127	127	127	127	153	153	191	191	191	191	191
	D	50	50	55	68	68	75	90	110	143	151	167

A¹⁾ = Dimension at DIN (resp. flanges ANSI and dimension DIN or flanges and dimension at DIN)

A²⁾ = Dimension at ANSI 150lbs (resp. flanges and dimension at ANSI)

Dimension B and diameter C change for solenoid drives for explosion-proof zone 1.

Please observe the dimensions of the attached relay combination for drives with "A1, A2, A3" in the type designation.

12.0 Declaration of Conformity

UNI-Geräte E. Mangelmann
Elektrotechnische Fabrik GmbH
Postfach 1261
D – 47649 Weeze



Konformitätserklärung *Declaration of Conformity*

Produkt <i>Product</i>	Sicherheitsabblaseventil <i>Safety blow-off valve</i>		
Handelsbezeichnung <i>Trade Mark</i>	Magnetventil <i>Solenoid Valve</i>		
Baureihe <i>Series</i>	4-EVS...-4Ü	10-EVS...Ü	40-EVS...Ü
Nennweite <i>Size</i>	Rp ¼" - Rp 2" DN 15 – DN 150	Rp ¼" , ½" DN 15 – DN 150	Rp ½"
EU-Richtlinien <i>EC-Directives</i>	97/23/EG 2006/95/EG 2004/108/EG	Druckgeräterichtlinie <i>Pressure Equipment Directive</i> Niederspannungsrichtlinie <i>Low-Voltage Directive</i> EMV-Richtlinie <i>EMC Directive</i>	
Angewandte technische Spezifikation <i>Applied Technical Specification</i>	DIN EN 264		
Typenprüfung <i>Type Examination</i>	DIN EN 264 TÜV Rheinland, Köln		
Überwachungsverfahren <i>Surveillance Procedure</i>	97/23/EG Bureau Veritas S.A., Paris Notified Body 0062		
Kennzeichnung <i>Marking</i>	98/37/EG 97/23/EG ¹⁾	≥ DN 200	CE 0062

Das Unternehmen UNI Geräte E. Mangelmann Elektrotechnische Fabrik GmbH bescheinigt hiermit, dass die o.a. Baureihe die grundsätzlichen Anforderungen der aufgeführten Richtlinien und Normen erfüllt.

UNI Geräte E. Mangelmann Elektrotechnische Fabrik GmbH confirms that the basic requirements of the above specified directives and standards are fulfilled.

Weeze, den 04.06.2007



Geschäftsführer
Managing Director



Leiter Konstruktion
Head of Design

1) Nicht aufgeführte Nennweiten fallen nicht in den Anwendungsbereich der 97/23/EG
Sizes not mentioned are not included in the EC-Directive 97/23/EG

250.000.084-02